

BLITZ™
TELÉFONO PARA MENSAJERÍA

Guía del Usuario



BLITZ™

USER GUIDE

SU000102C0A



User Guide

BLITZ™
MESSAGING PHONE



User Guide

Blitz™

CHAPTER 1. BEFORE USING Blitz™

BEFORE USING	6
INSIDE THE PACKAGE.....	6
HANDSET DESCRIPTIONS.....	7
KEYS DESCRIPTIONS.....	8
DISPLAY INDICATORS.....	10
INSTALL BATTERY.....	12
REMOVE BATTERY.....	13
CHARGING YOUR BATTERY.....	13
BATTERY HANDLING INFORMATION.....	14

CHAPTER 2. BASIC OPERATION

BASIC OPERATION	16
TURNING THE PHONE ON/OFF.....	16
ACCESSING THE MENU.....	16
MENU SUMMARY.....	17
MAKING A CALL.....	19
ANSWERING CALLS.....	19
MISSED CALL NOTIFICATION.....	19
WAIT/PAUSE FEATURE.....	20
ANSWERING A CALL.....	20

MAKING AN INTERNATIONAL CALL.....	20
3-WAY CALLING.....	21
CALL WAITING FUNCTION.....	21
CALLING A NUMBER FROM CONTACTS.....	21
ADJUSTING VOLUME.....	22
ADJUSTING THE CALL VOLUME.....	22
CALLER ID FUNCTION.....	22
VIBRATE ON/OFF MODE.....	22
SPEAKERPHONE MODE.....	22
USING AUTO KEYPAD LOCK FUNCTION.....	23
AVAILABLE OPTIONS DURING A CALL.....	23
MAKING AN EMERGENCY CALL.....	24
NAMES TO BE DIALED.....	25

CHAPTER 3. MEMORY FUNCTION

MEMORY FUNCTION	28
STORING A PHONE NUMBER.....	28
ENTERING LETTERS, NUMBERS & SYMBOLS.....	34
ONE, TWO, THREE-TOUCH DIALING.....	35

CHAPTER 4. MENU FUNCTION

CONTACTS	38
NEW CONTACT.....	38
CONTACT LIST.....	38
GROUPS.....	39
SPEED DIALS.....	42
IN CASE OF EMERGENCY.....	43
MY NAME CARD.....	45
RECENT CALLS	47
RECENT CALLS.....	47
MISSED.....	47
RECEIVED.....	48
DIALED.....	48
ALL.....	49
BLOCKED.....	49
VIEW TIMERS.....	50
SETTINGS	51
BLUETOOTH MENU.....	51
SOUNDS SETTINGS.....	54
DISPLAY SETTINGS.....	57
PHONE SETTINGS.....	60

CALL SETTINGS.....	67
MEMORY.....	69
PHONE INFO.....	72
VOICE TOOLS	74
VOICE COMMANDS.....	74
TOOLS	79
CALCULATOR.....	79
CALENDAR.....	79
ALARM CLOCK.....	82
WORLD CLOCK.....	83
NOTEPAD.....	84
STOP WATCH.....	85
MY VERIZON	86
MY VERIZON.....	86

CHAPTER 5. MEDIA CENTER

microSD	88
USING THE microSD CARD.....	88
MEDIA CENTER	89
MUSIC & TONES.....	89
PICTURES.....	94

GAMES	96
MOBILE WEB	97
BROWSE & DOWNLOAD	98
EXTRAS	99
MEDIA CENTER INFO.....	99

CHAPTER 6. MESSAGING MENU

MESSAGING	102
WHEN A NEW MESSAGE ARRIVES	102
NEW MESSAGE.....	102
INBOX	105
SENT	105
DRAFTS	106
VOICEMAIL	106
MOBILE IM	107
EMAIL	108
CHAT	108
ERASE ALL	108
SETTINGS	109

CHAPTER 7. SAFETY AND WARRANTY

SAFETY	112
SAFETY INFORMATION FOR WIRELESS HANDHELD PHONES	112
SAFETY INFORMATION FOR FCC RF EXPOSURE	115
SAR INFORMATION	115
FCC HEARING-AID COMPATIBILITY (HAC) REGULATIONS FOR WIRELESS DEVICES.....	116
FDA CONSUMER UPDATE.....	118
AVOID POTENTIAL HEARING LOSS.....	122
FCC COMPLIANCE INFORMATION	124
WARRANTY	125
12 MONTH LIMITED WARRANTY.....	125
INDEX LIST.....	127

CHAPTER 1

BEFORE USING Blitz™

This chapter provides important information about using the Blitz™ including:

- Inside the package
- Handset descriptions
- Keys descriptions
- Display indicators
- Install battery
- Remove battery
- Charging your battery
- Battery handling information

INSIDE THE PACKAGE

This package should include all items pictured below. If any are missing or different, immediately contact the retailer where you purchased the phone.



Handset



Standard Battery

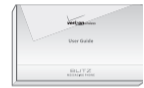

User Guide



USB Cable



Battery Cover



QRG (Quick Reference Guide)



Wall Charger

HANDSET DESCRIPTIONS

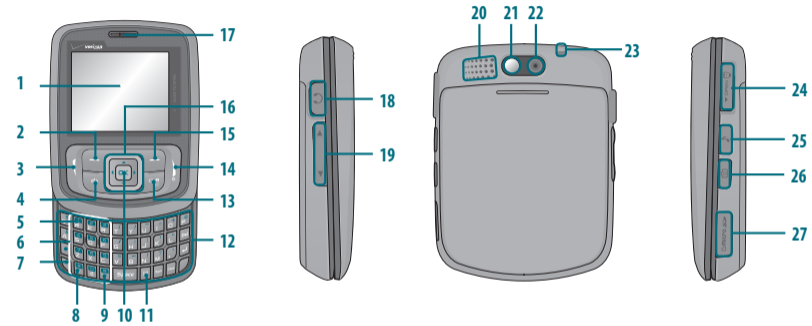

- | | | | |
|---------------------|---------------------------|--------------------------|--------------------------|
| 1. Display Screen | 8. International Dial Key | 15. Right Soft Key | 22. Camera Lens |
| 2. Left Soft Key | 9. Vibrate Mode Key | 16. Directional Key | 23. Wrist Strap Eyelet |
| 3. SEND Key | 10. Menu/OK Key | 17. Earpiece | 24. Charging / Data Jack |
| 4. Speakerphone Key | 11. My Messaging Key | 18. Headset Jack | 25. Music Key |
| 5. Voicemail Key | 12. QWERTY Keyboard | 19. Volume Keys | 26. Camera Key |
| 6. Dialing Keypad | 13. CLR or AVR Key | 20. External Speaker | 27. microSD Card Slot |
| 7. Microphone | 14. END Key | 21. Self-Portrait Mirror | |









KEYS DESCRIPTIONS









The following list correlates to the previous page's phone illustration.

- 1. Display Screen:** This screen displays all the information needed to operate your phone.
- 2. [] Left Soft Key:** Press to display the Message menu or access the function listed above the key.
- 3. [] SEND Key:** Press to make or receive a call. In standby mode, press to access your All Calls list.
- 4. [] Speakerphone Key:** Press to turn Speakerphone On or Off.
- 5. [] Voicemail Key:** Press and hold to automatically dial your voicemail system.
- 6. Dialing Keypad:** In idle mode, press to enter phone numbers.
- 7. Microphone:** Allows the other caller to hear you clearly when you are speaking to them.
- 8. [] International Dial Key:** Press and hold to enter a plus "+". A "+" is reserved for international dialing code.
- 9. [] Vibrate Mode Key:** Press and hold to place your device in Vibrate mode.
- 10. [OK] Menu/OK Key:** Allows you to access the menu screen. It also allows you to accept choices when navigating through a menu.
- 11. [] My Messaging Key:** Press to access the My Messaging menu.
- 12. QWERTY Keyboard:** Press to enter numbers, letters, and characters using a full Qwerty keypad interface.
- 13. [CLR/AVR] CLR/AVR Key:** When entering a phone number or text, press to delete a single space or character. Press and hold to delete entire words. Press this key once in a menu to go back one level. In idle mode, press and hold to activate VoiceSignal™. In WAP applications mode, press to retrieve the last URL, press and hold to retrieve the home page URL. During download mode, press to cancel the download.



- 14. [] END Key:** Press to turn the phone on/off, end a call or browser session, and/or return to idle mode.
- 15. [] Right Soft Key:** Press to display Contacts or to access the function listed above the key.
- 16. [] Directional Key:** The Directional Key allows you to scroll through phone menu options and provides a shortcut to phone functions from standby mode. For more information on personalizing set shortcut keys, see "Set Shortcuts" on page 60.
- 17. Earpiece:** The earpiece allows you to hear the other caller.
- 18. Headset Jack:** Plug in the Headset Connector here to use a headset.
- 19. [] Volume Keys:** Allows you to adjust the master volume in standby mode or adjust the voice volume during a call.
- 20. External Speaker:** Music, Ringtones, and Sounds are played through the speaker.
- 21. Self-Portrait Mirror:** Displays your reflection when taking pictures.
- 22. Camera Lens:** The lens of your built-in camera.
- 23. Wrist Strap Eyelet:** Accessory eyelet (optional straps and lanyards - purchased separately).
- 24. Charging / Data Jack:** Plug in the Wall Charger or USB Cable.
- 25. [] Music Key:** In idle mode, press to activate the Music player.
- 26. [] Camera Key:** Press to access Camera Viewfinder mode.
- 27. microSD Card Slot:** You can insert a microSD™ memory card here to increase memory capacity.











DISPLAY INDICATORS

Icon	Icon Discriptions
 D Signal Strength: CDMA IS 95 service available.	
 1X Signal Strength: 1X service is available.	
 Airplane Mode: Transmitting and receiving information is restricted.	
 Roaming: The phone is outside of the home service area.	
 SSL (Secured Socket Layer): Indicates that secure communication between client and server has been established during data communication using encryption.	
 Voice Privacy: Indicates Voice Privacy mode is active.	
 Data Call: Data Session in progress	
 Dormant: Phone is in a dormant state during a data call. Phone reverts to Dormant mode when there hasn't been activity on a page for some time — the connection is still active and you can make and receive calls.	
 No Service: Phone cannot receive a signal from the system.	

Icon	Icon Discriptions
 TTY: TTY mode is active.	
 Voice Call: A call is in progress. * No icon indicates the phone is in standby mode.	
 GPS Icon: Location Service of your phone is E911/Location On.	
 Bluetooth: Indicates Bluetooth mode.	
 Bluetooth Active: Indicates Bluetooth Active mode.	
 Bluetooth Conncted: Indicates Bluetooth Device is connected.	
 Battery Level: Battery charging level — the more blocks, the stronger the charge.	
 AVR Active: AVR mode is active.	
 AVR Listening: Indicates AVR listening.	

Icon	Icon Discriptions
 All Sounds Off: Ringer volume is set to off.	
 Alarm Only: Phone will alert you with an alarm tone.	
 Vibrate Only: Phone will vibrate when call is received.	
 Speakerphone: Speakerphone mode is active.	
 Missed Calls: Indicates you have missed calls.	
 Message: Indicates you have new message.	
 Calendar Appointment: Event Alarm is active.	
 Voicemail: Indicates you have voicemail messages.	
 Alarm On: Appears when an alarm is set.	

Recent Calls Icon			
	Dialed Call		Missed Call
	Received Call		

New Contacts Icon			
	Mobile1		Group
	Mobile2		Picture
	Home		Ringtone
	Work		Fax
	E-mail 1		Speed Dial
	E-mail 2		

Messages Icon			
	New/Unread Message		Opened Download Picture Message
	Opened/Read Message		Corrupt Message
	Message Delivered		Pending Message Send
	Incomplete Delivery		Unread MMS
	Sent Message, Delivery Failed		Read MMS
	Message Locked		Unread WAP Push
	Text Message Draft		Read WAP Push
	Picture Message Draft		Multiple Message Delivered
	Unopened Message Notification		Multiple Message Failed

Messages Icon			
	Multiple Message Incomplete		Multiple SMS/MMS Ack
	Multiple Message Pending		

INSTALL BATTERY

1. Remove the battery cover from the unit.
2. Slide the battery into the slot located at the bottom of the unit and press until you hear the "click".



REMOVE BATTERY

1. To remove the battery, push down on the top of the battery while inserting your finger into the slot and pulling up from the back of the battery and slide it out.
2. Align the cover tabs with the slots at the top of the device and slide the battery cover back onto the unit.

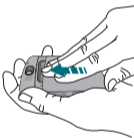

If the battery is not correctly placed in the compartment, the handset will not turn on and/or the battery may detach during use.

CHARGING YOUR BATTERY

1. To charge the phone, open the Charging/Data Jack cover on the Right Side of the phone, and connect the charger adapter. Plug the other end into a standard outlet.
2. To remove the adapter connection, squeeze the adapter's side buttons (1) and pull.



- When you charge the battery with the phone power off, you will see a charging status screen. You cannot operate the phone until it is powered on.
- The battery is not fully charged at the time of purchase. Fully charge the battery before use.
- It is more efficient to charge the battery with the handset powered off.
- Battery operating time gradually decreases over time.
- If the battery fails to perform normally, you may need to replace the battery.

BATTERY HANDLING INFORMATION

DO'S

- Only use the battery and charger approved for use with the Blitz™.
- Only use the battery for its original purpose.
- Try to keep batteries in a temperature between 41 °F (5 °C) and 95 °F (35 °C). If the battery is stored in temperatures above or below the recommended range, give it time to warm up or cool down before using.
- Completely drain the battery before recharging.
- Store the discharged battery in a cool, dark, and dry place.
- Purchase a new battery when its operating time gradually decreases after fully charging.
- Properly dispose of the battery according to local laws.

DON'TS

- Don't attempt to disassemble the battery – it is a sealed unit with no serviceable parts.
- Don't accidentally short circuit the battery by carrying it in your pocket or purse with other metallic objects such as coins, clips and pens. This may critically damage the battery.
- Don't leave the battery in extremely hot or cold temperatures. Otherwise, it could significantly reduce the capacity and lifetime of the battery.
- Don't dispose of the battery by placing into a fire.

BASIC OPERATION

This chapter addresses and explains the basic features of your phone including:

- | | |
|------------------------------|---------------------------------|
| Turning the phone on/off | Call waiting function |
| Accessing the menu | Calling a number from contacts |
| Menu summary | Adjusting volume |
| Making a call | Adjusting the call volume |
| Answering calls | Caller ID function |
| Missed call notification | Vibrate on/off mode |
| Wait/Pause feature | Speakerphone mode |
| Answering a call | Using auto keypad lock function |
| Making an international call | Available options during a call |
| 3-way calling | Making an emergency call |
| | Names to be dialed |

TURNING THE PHONE ON/OFF

TURNING THE PHONE ON

1. Press and hold the END Key  until your display turns on and the tone sounds.

- If "Enter Lock Code" appears on the display, enter your 4-digit lock code to unlock your phone.
- The default lock code is the last 4 digits of your Mobile Telephone Number.









TURNING THE PHONE OFF

1. Press the OK Key  [OK] to unlock the keypad, then press and hold the END Key  until your display turns off.

- Immediately change or recharge the battery when "BATTERY LOW" appears on the display. Memory may possibly be damaged if the phone turns off due to the battery completely draining.
- Turn the phone off before removing or replacing the battery. If the phone is on, unsaved data may be lost.

ACCESSING THE MENU

Your phone can be customized via the menu. Each function can be accessed by scrolling with the Directional Key  or by pressing the number that corresponds with the menu item.

1. To access the menu in idle mode, press the OK Key  [OK] to unlock the keypad, then press the OK Key  [MENU].
2. To scroll through the menu, press the Directional Key  up, down, left or right.
3. To return to the previous page, press the CLR Key . To exit the current menu and return to the idle mode, press the END Key .
4. In idle mode, press the OK Key  [OK] to unlock the keypad, then press the Left Soft Key  [Message] to open the Messaging menu. Or, press the Right Soft Key  [Contacts] to open your Contacts list.

 All directions in this manual are based on the [Tab Main Menu Setting](#), and [Charming Display Theme](#), which are the default settings.

MENU SUMMARY

Main Menu	2 ND DEPTH	3 RD DEPTH
MEDIA CENTER	1. Music & Tones	1. Get New Ringtones 2. My Ringtones 3. My Music 4. My Sounds 5. Sync Music
	2. Pictures	1. Get New Pictures 2. My Pictures 3. Take Picture 4. Online Album
	3. Games	1. Get New Applications
	4. Mobile Web	1. Get New Applications Mobile Email VZ Navigator
	5. Browse & Download	1. Get New Applications
	6. Extras	1. Get New Applications
MESSAGING	1. New Message	1. TXT Message 2. Picture Message 3. Voice Message
	2. Inbox	
	3. Sent	



Main Menu	2 ND DEPTH	3 RD DEPTH
MESSAGING	4. Drafts 5. Voicemail 6. Mobile IM 7. Email 8. Chat	1. Get New Applications Mobile IM Mobile Email Mobile Web Mail
CONTACTS	1. New Contact 2. Contact List 3. Groups 4. Speed Dials 5. In Case of Emergency 6. My Name Card	
RECENT CALLS	1. Missed 2. Received 3. Dialed 4. Blocked ("Blocked" appears only when Call Restriction is set) 5. All 6. View Timers	

Main Menu	2 ND DEPTH	3 RD DEPTH
SETTINGS & TOOLS	1. My Verizon 2. Tools	1. Voice Commands 2. Calculator 3. Calendar 4. Alarm Clock 5. World Clock 6. Notepad 7. Stop Watch
	3. Bluetooth Menu 4. Sounds Settings	1. Add New Device 1. Call Sounds 2. Alert Sounds 3. Keypad Volume 4. Service Alerts 5. Device Connect 6. Power On/Off 7. Open/Close Sound
	5. Display Settings	1. Banner 2. Backlight 3. Wallpaper 4. Display Themes 5. Main Menu 6. Dial Fonts

Main Menu	2 ND DEPTH	3 RD DEPTH
SETTINGS & TOOLS	6. Phone Settings	7. Clock Format 1. Airplane Mode 2. Set Shortcuts 3. Voice Commands 4. Language 5. Location 6. Security 7. System Select 8. NAM Selection
	7. Call Settings	1. Answer Options 2. End Call Options 3. Auto Retry 4. TTY Mode 5. One Touch Dial 6. Voice Privacy 7. DTMF Tones
	8. Memory	1. Save Options 2. Phone Memory 3. Card Memory
	9. Phone Info	1. My Number 2. SW/HW Version 3. Icon Glossary 4. Software Update

MAKING A CALL



- Slide out the QWERTY keyboard and from standby mode enter the phone number (include the area code if needed). Press the SEND Key .

- To erase one digit at a time press the CLR Key .
- To erase the entire number, press and hold the CLR Key .
- When you place or receive a call from phone numbers stored in your contact list with a contact name, the name will be displayed.

- To end a call, press the END Key .

- If you activate the "AUTO RETRY" function, the phone will automatically re-dial the number (Refer to [page 68](#)).
- You can also place calls using Voice-Activated Dialing. Please refer to [page 74](#) for more details.

ANSWERING CALLS

- When your phone rings or vibrates, press the SEND Key  to answer the incoming call. (Depending on your phone's settings, you may also answer incoming calls by opening the phone or by pressing any key.)
- To ignore incoming calls, press the Right Soft Key  [Ignore].
- To end a call, press the END Key .

 In "Auto w/ Hands-free" a call is automatically answered after a preset number of ring tones (Refer to [page 67](#)).





MISSED CALL NOTIFICATION

When an incoming call is not answered, the Missed Call logo appears on the display.

TO DISPLAY THE MISSED CALL ENTRY FROM THE NOTIFICATION SCREEN:

- Highlight the entry "View Now" and press the OK Key .
- To dial the phone number, press the SEND Key .

TO DISPLAY A MISSED CALL ENTRY FROM STANDBY MODE:

- From standby mode, press the OK Key  [OK] to unlock the keypad, then press the OK Key  [MENU], then press the Directional Key  right once for the "RECENT CALLS" menu.
- Slide out the QWERTY keyboard, and then press "1. Missed".
- Highlight the entry you wish to view, then press the OK Key  [OPEN].
- To dial the phone number, press the SEND Key .

WAIT/PAUSE FEATURE

Pauses are used for automated systems (i.e., voice mail or calling cards). Insert a pause after a phone number and then enter another group of numbers. The second set of numbers is dialed automatically after the pause. This feature is useful for dialing into systems that require a code.

Wait (W)

The phone stops dialing until you press the Left Soft Key [Release] to advance to the next number.

2-Sec Pause

The phone waits 2 seconds before sending the next string of digits automatically.

1. Slide out the QWERTY keyboard, and from standby mode enter the phone number.
2. Press the Right Soft Key [Options].
3. Press the Directional Key up or down to select pause type, then the OK Key [OK]. "2-Sec Pause/Wait".
4. Enter additional number(s) (pin number or credit card number).
5. Press the SEND Key to dial or the Left Soft Key [Save].

ANSWERING A CALL

1. If your phone is set to "Slide Open" for "Answer Options," simply open the phone to answer a call. If your phone is set to "Any Key" for "Answer Options," press any key to answer a call. If your phone is set to "Auto w/ Hands-free" for "Answer Options," calls are answered automatically with a 5 second delay. ("Auto w/ Hands-free" is available only when connected to a headset or hands-free device.) For information on how to set your Answer Options, see page 67.

2. To end the call, press the END Key.

MAKING AN INTERNATIONAL CALL

1. Slide out the QWERTY keyboard, and then press and hold the * Key. The + required for international calls will be displayed.
2. Enter the country code, area code, and phone number, then press the SEND Key.
3. To end the call, press the END Key.

3-WAY CALLING

With 3-Way Calling, you can talk to two people at the same time. When using this feature, the normal airtime rates will be applied for each of the two calls.

1. Slide out the QWERTY keyboard, and then enter the phone number you wish to call and then press the SEND Key.
2. Once you have established the connection, enter the second phone number you wish to call and then press the SEND Key again.
3. When you're connected to the second party, press the SEND Key again to begin your 3-Way call.



If one of the people you called hangs up during your call, you and the remaining caller stay connected. If you initiated the call and are the first to hang up, all three CALLS are disconnected.

CALL WAITING FUNCTION

If you are on a call and you receive another incoming call, you will hear two beeps and the caller's phone number will appear on the display. With Call Waiting, you may put the active call on hold while you answer the other incoming call. To use Call Waiting:

1. To answer another call while on the phone, press the SEND Key. This places the first call on hold. To switch back to the first caller, press the SEND Key again.

CALLING A NUMBER FROM CONTACTS



1. From standby mode, press the OK Key [OK] to unlock the keypad, then press the Right Soft Key [Contacts].
2. Press the Directional Key up or down to select the Contact entry then press the OK Key [VIEW].
3. Press the Directional Key up or down to select the phone number.
4. Press the SEND Key to place the call.



Pressing the Directional Key up or down to select the "Contact entry" and then pressing the Send Key will dial the Default Number of the Contact entry automatically. If multiple numbers are saved in the "Contact entry", press the Directional Key up or down to select the "Contact entry" and then press the Directional Key left or right to select the number you want to dial. Then press the Send Key.



ADJUSTING VOLUME

To adjust the master volume:

1. In idle mode, press the OK Key  [OK] to unlock the keypad, then press the Volume Keys  up or down.
2. Select one of the following options and press the OK Key  [SET] to save it.
 - All Sounds Off
 - Alarm Only
 - Vibrate Only
 - Low / • Medium Low / • Medium / • Medium High / • High

-  • Press the Volume Keys  up or down to adjust Earpiece volume during a call.
- To play a ringtone, press the Left Soft Key  [Play].

ADJUSTING THE CALL VOLUME



During a call, if you want to adjust the earpiece volume, press the Volume Keys  up or down. Press the Volume Keys  up to increase the volume level and the Volume Keys  down to decrease the level. In Idle mode, you can also adjust the ringer volume by following the same steps.

CALLER ID FUNCTION

Caller ID displays the number of the person calling when your phone rings. If the caller's identity is stored in Contacts, the name appears on the screen. The caller ID is stored in the Recent Calls Menu.



VIBRATE ON/OFF MODE

Vibrate Mode mutes key tones and activates an alert for an incoming call or message. To activate Vibrate Mode:

1. From the idle screen, slide out the QWERTY keyboard, and then press and hold the # Key .
2. To return to a "Medium High" volume, from the idle screen press and hold the # Key  again.

SPEAKERPHONE MODE

The Speakerphone feature lets you hear audio through the speaker and talk without holding the phone.

To activate the Speakerphone in idle mode or while on a call, press the Speakerphone Key . If you press the Speakerphone Key  when you are not on a call, Speakerphone mode will be active for one minute, then turn itself off automatically.

USING AUTO KEYPAD LOCK FUNCTION

When the Slide is closed, the Side Keys and the Directional Key  are locked. To unlock them, press any key, "PRESS OK TO UNLOCK KEYPAD" displays, then press the OK Key  [OK].



 You can open the slide to unlock the keypad.

AVAILABLE OPTIONS DURING A CALL

During a phone call, you can access the following features by pressing the Right Soft Key  [Options]:



MESSAGING

To access the Messaging Menu during a call:

1. Press the OK Key  [OK] to unlock the keypad, then press the Right Soft Key  [Options], then slide out the QWERTY keyboard, and press "1. Messaging".



CONTACT LIST

To view your Contact List during a call:

1. Press the OK Key  [OK] to unlock the keypad, then press the Right Soft Key  [Options], then slide out the QWERTY keyboard, and press "2. Contact List".



RECENT CALLS

To view your Recent Calls list during a call:

1. Press the OK Key  [OK] to unlock the keypad, then press the Right Soft Key  [Options], then slide out the QWERTY keyboard, and press "3. Recent Calls".

BLUETOOTH MENU



To access the Bluetooth Menu during a call:

1. Press the OK Key  [OK] to unlock the keypad, then press the Right Soft Key  [Options], then slide out the QWERTY keyboard, and press "4. Bluetooth Menu".

 If an Audio device is connected, "Audio To Phone/Audio To Device" is displayed in the options menu instead of "Bluetooth Menu".



MAIN MENU

To access the Main Menu during a call:

1. Press the OK Key  [OK] to unlock the keypad, then press the Right Soft Key  [Options], then slide out the QWERTY keyboard, and press "5. Main Menu".
2. Press the Directional Key  up, down, left or right to scroll through the menu screens.

NOTEPAD

To compose and send notes during a call:

1. Press the OK Key  [OK] to unlock the keypad, then press the Right Soft Key  [Options], then slide out the QWERTY keyboard, and press "6. Notepad".

MAKING AN EMERGENCY CALL

The 911 feature automatically places the phone in the Emergency Call Mode when you dial the preprogrammed emergency number, 911. It also operates in Lock Mode and out of the service area.

911 IN LOCK MODE

To make an emergency call in Lock Mode:

1. Slide out the QWERTY keyboard, and then enter "911" and then press the SEND Key .
2. The call connects.
3. The phone maintains the Emergency Mode for 5 minutes. When the call ends, the phone returns to Lock Mode.

911 USING ANY AVAILABLE SYSTEM

To make an Emergency Call using any available system:

1. Slide out the QWERTY keyboard, and then enter "911" and then press the SEND Key .
2. The call connects.
3. The phone will stay in Emergency Mode for 5 minutes. While the phone is in the Emergency Mode for 5 minutes, the phone can receive an incoming call from any available system or you can make outgoing calls even in the Emergency Callback Mode. In this case, making a call can automatically end the Emergency Callback Mode.





The 911 call does not appear in the recent call list.

NAMES TO BE DIALED

Allows you to dial the number associated with a specific word.

For example, to call "1-800-FLOWER":

1. Slide out the QWERTY keyboard, and then enter "1-800" and then press and hold the Mode Change Key .
2. Enter "FLOWER" with the QWERTY Keyboard and then press the SEND Key  to connect.



- If Alphabet Mode icon is turned on only capital letters will be appeared.
- Pressing the Mode Change Key  changes the display Number Mode icon  to Alphabet Mode icon .

CHAPTER 3

MEMORY FUNCTION

This chapter addresses memory functions including:

- Storing a phone number
- Entering letters, numbers & symbols
- One, Two, Three-touch dialing

STORING A PHONE NUMBER

The Contact List stores up to 1000 entries.

ADDING A NEW CONTACT

1. From standby mode slide out the QWERTY keyboard, and then enter the phone number you want to save.
2. Press the Left Soft Key [Save].
3. Press the Directional Key up or down to select "Add New Contact", then press the OK Key [OK].
4. Press the Directional Key up or down to select the type of phone number you want to save, then press the OK Key [OK].
Mobile 1/Mobile 2/Home/Work/Fax

 Use Update Existing to add another phone number to a contact already stored in memory.

5. Enter a name for the phone number (up to 32 characters), then press the OK Key [SAVE].
6. "CONTACT SAVED" displays, then the phone number reappears on the screen. Press the End Key to exit, or press the Send Key to call the number.

Press the Right Soft Key [Options] to access the following options:

- **2-Sec Pause:** Insert a 2-sec Pause in the number.
- **Wait:** Insert a Wait pause in the number.
- **New TXT Message:** Send a text message to the contact.
- **New Picture Message:** Send a picture message to the contact.
- **New Voice Message:** Send a voice message to the contact.

OPTIONS TO CUSTOMIZE YOUR CONTACTS

Once the basic phone number and name information is stored in your Contacts, you can edit and/or customize the entries.

1. From standby mode, press the OK Key [OK] to unlock the keypad, then press the Right Soft Key [Contacts], then press the Directional Key up or down to highlight the Contact entry you want to edit.
2. Press the Left Soft Key [Edit] to access the Edit Contact screen.
3. Press the Directional Key up or down to highlight the information field you want to customize. Additional fields include:
Name/Mobile 1/Home/Work/E-mail 1/Group/Picture/Ringtone/
Mobile 2/Fax/E-mail 2

4. Slide out the QWERTY keyboard, and then change the data as necessary, then press the OK Key [SAVE] to save.

ADDING OR CHANGING GROUPS

To organize your Contacts into groups:

1. From standby mode, press the OK Key [OK] to unlock the keypad, then press the Right Soft Key [Contacts], then press the Directional Key up or down to highlight an entry.
2. Press the Left Soft Key [Edit].
3. Press the Directional Key up or down to highlight "Group" then press the Left Soft Key [Set].
4. Press the Directional Key up or down to select the Group, then press the OK Key [OK].
No Group/Family/Work
5. Press the OK Key [SAVE] to save.









CHANGING THE CALL RINGTONE

To identify who is calling by setting different ringtones for different phone numbers in your Contacts:

1. From standby mode, press the OK Key [OK] to unlock the keypad, then press the Right Soft Key [Contacts], then press the Directional Key up or down to highlight an entry.
2. Press the Left Soft Key [Edit].
3. Press the Directional Key up or down to highlight Default under "Ringtone", then press the Left Soft Key [Set].
4. Press the Directional Key up or down to select the new ringtone, then press the OK Key [OK].
 Press the Left Soft Key [Play] to listen to a highlighted ringtone before you press the OK Key [OK].
5. Press the OK Key [SAVE] to save.





ADDING OR CHANGING THE PICTURE ID



To select a picture or graphic to assign to a Caller ID:

1. From standby mode, press the OK Key  [OK] to unlock the keypad, then press the Right Soft Key  [Contacts], then press the Directional Key  up or down to highlight an entry.
2. Press the Left Soft Key  [Edit].
3. Press the Directional Key  up or down to highlight "Picture", then press the Left Soft Key  [Set].
4. Press the Directional Key  up, down, left or right to select a picture, then press the OK Key  [OK].
5. When completed, press the OK Key  [SAVE].

ADDING OR CHANGING AN EMAIL ADDRESS









To enter or add an Email address to a Contact entry:

1. From standby mode, press the OK Key  [OK] to unlock the keypad, then press the Right Soft Key  [Contacts], then press the Directional Key  up or down to highlight an entry.
2. Press the Left Soft Key  [Edit].

3. Press the Directional Key  up or down to highlight "E-mail 1" or "E-mail 2".
4. Slide out the QWERTY keyboard, and then enter an Email address, then press the OK Key  [SAVE] to save.







ADDING A SPEED DIAL ENTRY





To add an entry to Speed Dial:

1. From standby mode, press the OK Key  [OK] to unlock the keypad, then press the Right Soft Key  [Contacts], then press the Directional Key  up or down to highlight an entry.
2. Press the Left Soft Key  [Edit].
3. Press the Directional Key  up or down to highlight the phone number you want to add to Speed Dial, then press the Right Soft Key  [Options].
4. Slide out the QWERTY keyboard, and then select "1. Set Speed Dial", then press the OK Key  [OK].
5. Press the Directional Key  up or down to select a Speed Dial location, then press the OK Key  [SET].







6. Press the Directional Key  up or down to select "Yes" to save, then press the OK Key  [OK].
7. Press the OK Key  [SAVE] to save.

EDITING CONTACTS ENTRIES**ADDING A PHONE NUMBER FROM THE STANDBY MODE**

1. From standby mode slide out the QWERTY keyboard, and then enter the phone number you want to save (up to 48 digits).
2. Press the Left Soft Key  [Save].
3. Press the Directional Key  up or down to highlight "Update Existing", then press the OK Key  [OK].
4. Press the Directional Key  up or down to highlight the existing Contact entry, then press the OK Key  [OK].
5. Press the Directional Key  up or down to highlight the phone number type, then press the OK Key  [OK].
Mobile 1/Mobile 2/Home/Work/Fax

6. If a phone number is already assigned to the item you selected, press the Directional Key  up or down to select "Yes" or "No", then press the OK Key  [OK]. If nothing is currently assigned to the phone number item, press the OK Key  [SAVE].
7. "CONTACT SAVED" displays, then the phone number reappears on the screen. Press the End Key  to exit, or press the Send Key  to call the number.

ADDING A PHONE NUMBER FROM THE CONTACT LIST SCREEN

1. From standby mode, press the OK Key  [OK] to unlock the keypad, then press the Right Soft Key  [Contacts]. Your Contacts display alphabetically.
2. Press the Directional Key  up or down to highlight the Contact entry you want to edit, then press the Left Soft Key  [Edit].
3. Press the Directional Key  up or down to highlight the phone number field you want to add, slide out the QWERTY keyboard, and then enter the number, then press the OK Key  [SAVE] to save. A confirmation message appears.

DEFAULT NUMBERS

The phone number saved when a Contact is created is the Default Number. If more than one number is saved in a Contact entry, another number can be set as the Default Number.



The Default Number cannot be deleted. The entire Contact entry can be deleted or another number can be assigned as the Default Number allowing you to delete the original number and keep the Contact entry.

CHANGING THE DEFAULT NUMBER

1. From standby mode, press the OK Key [OK] to unlock the keypad, then press the Right Soft Key [Contacts]. Your Contacts display alphabetically.
2. Press the Directional Key up or down to highlight the Contact entry you want to edit, then press the Left Soft Key [Edit].
3. Press the Directional Key up or down to highlight the phone number you want to assign as the Default Number, then press the Right Soft Key [Options].
4. Press the Directional Key up or down to highlight "2. Set As Default", then press the OK Key [OK].
5. Press the Directional Key up or down to select "Yes".

6. Press the OK Key [OK]. A confirmation message appears.
7. Press the OK Key [SAVE] to save.

EDITING STORED PHONE NUMBERS

1. From standby mode, press the OK Key [OK] to unlock the keypad, then press the Right Soft Key [Contacts]. Your Contacts display alphabetically.
2. Press the Directional Key up or down to highlight the Contact entry you want to edit, then press the Left Soft Key [Edit].
3. Press the Directional Key up or down to highlight the phone number.
4. Slide out the QWERTY keyboard, and then edit the phone number as necessary, then press the OK Key [SAVE].

EDITING STORED NAMES

1. From standby mode, press the OK Key [OK] to unlock the keypad, then press the Right Soft Key [Contacts]. Your Contacts display alphabetically.
2. Press the Directional Key up or down to highlight the Contact entry you want to edit, then press the Left Soft Key [Edit].

3. Slide out the QWERTY keyboard, and then edit the name as necessary, then press the OK Key [SAVE].

DELETING

DELETING A PHONE NUMBER FROM A CONTACT

1. From standby mode, press the OK Key [OK] to unlock the keypad, then press the Right Soft Key [Contacts].
2. Press the Directional Key up or down to highlight the Contact entry, then press the Left Soft Key [Edit].
3. Press the Directional Key up or down to highlight the phone number to be deleted.
4. Press and hold the Clear Key to delete the number.
5. Press the OK Key [SAVE]. A confirmation message appears.

DELETING A CONTACT ENTRY

1. From standby mode, press the OK Key [OK] to unlock the keypad, then press the Right Soft Key [Contacts].
2. Press the Directional Key up or down to highlight the Contact entry to be deleted.

3. Press the Right Soft Key [Options].
4. Slide out the QWERTY keyboard, and then press "2. Erase".
5. Press the Directional Key up or down to select "Yes".
6. Press the OK Key [OK]. A confirmation message appears.

DELETING A SPEED DIAL

1. From standby mode, press the OK Key [OK] to unlock the keypad, then press the OK Key [MENU].
2. Press the Directional Key up or down to highlight "4. Speed Dials", then press the OK Key [OK].
3. Press the Directional Key up or down to highlight the Speed Dial number.
4. Press the Right Soft Key [Remove].
5. Press the Directional Key up or down to select "Yes".
6. Press the OK Key [OK]. A confirmation message appears.

ENTERING LETTERS, NUMBERS & SYMBOLS

Your device has a QWERTY keyboard that provides a superior typing experience on a small handheld device for easy and comfortable input. You can use all of the handset functions with the keyboard either closed or open. When you slide open the keyboard you have the extra benefit of a full messaging keyboard.

Your device has dictionaries for English. The appropriate dictionary is activated automatically when you select a language on your device.

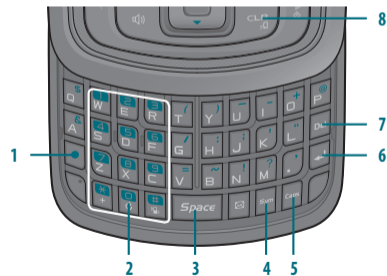

Your device uses the active dictionary to suggest corrections or complete the word you're typing.

- [] Mode Change Key:**
 - When in idle mode :
 - Slide out the QWERTY keyboard, and then press to change between entering numbers and letters that appear on the same key.
 - Press and hold to lock in numeric mode or text entry mode.
 - When in Text entry mode :
 - Press to change between entering upper and lower case letters.
 - Press and hold to lock in numeric or text entry mode.
- [] Word Change Key:** When in text entry mode, press to select the next matching word.
- [Space] Space Key:** Press to accept a word and add a space.
- [] Symbols Key:** Press to open symbols list.
- [] Caps Key:** Press to select a letter case for the standard text [Abc] input mode. [Abc], [ABC] and [abc] indicate the standard text input.
- [] Enter Key:** Press to insert a carriage return.

- [Del] Del Key:** When in a Text entry field and in entry mode, press to delete the character to the left of the cursor. Press and hold to delete the entire word or character string that was just entered.
- [CLR/AVR] CLR/AVR Key:** When in a Text entry field and in entry mode, press to delete the character to the left of the cursor. Press and hold to delete the entire word or character string that was just entered.

 For best performance in low-light environments, your handset includes a backlight feature that can illuminate both the display and the keyboard so you can keep reading and typing. (Please refer to [page 58](#) for more details on "Backlight".)

ONE, TWO, THREE-TOUCH DIALING

Ideal for frequently dialed numbers, this feature allows contact entries to be dialed via the keypad with only one, two, or three key presses.

ONE-TOUCH DIALING:

1-9 : Slide out the QWERTY keyboard, and then press and hold the number you wish to connect to for more than 1 second.

TWO-TOUCH DIALING:

10-21 : Slide out the QWERTY keyboard, and then press the first digit and press and hold the second digit of the number to dial.

97, 98, and 99 : Speed Dial entries **97(#BAL)**, **98(#MIN)**, and **99(#PMT)** are already assigned to Verizon Wireless Account Information.

- #BAL** is a VZW Customer Service VRU number (Free call) that provides customers information about their Verizon Wireless billing balance.
- #MIN** is a VZW Customer Service VRU number (Free call) that provides customers information about their Verizon Wireless usage.
- #PMT** is a VZW Customer Service VRU number (Free call) that allows a user to make a bill payment, either with a payment option they have already set up, or using a new, one time payment option.

THREE-TOUCH DIALING:

Slide out the QWERTY keyboard, and then press the first and second digits and press and hold the third digit of the number to dial.

411 : Speed Dial entry **411 (Directory Assistance)** is already assigned to Directory Assistance.

- **Directory Assistance** is a VZW Wireless Directory Assistance service that provides directory listing database information.

MENU FUNCTION

This chapter addresses accessing the menu and using its functions and features to customize your phone.







New contact	All	Voice commands
Contact list	Blocked	Calculator
Groups	View timers	Calendar
Speed dials	Bluetooth menu	Alarm clock
In case of emergency	Sounds settings	World clock
My name card	Display settings	Notepad
Recent calls	Phone settings	Stop watch
Missed	Call settings	My Verizon
Received	Memory	
Dialed	Phone info	

Entries can be retrieved by name or group.

NEW CONTACT

To add a new number to your Contacts List:

 Using this submenu, the number is saved as a new Contact.
To save the number into an existing Contact, edit the Contact entry.

1. From standby mode, press the OK Key  [OK] to unlock the keypad, then press the OK Key  [MENU], then slide out the QWERTY keyboard, and press **1. New Contact**.
2. Enter the name, then press the Directional Key  down. To change the input mode, press the Left Soft Key  [Abc].
3. Press the Directional Key  down to enter information in other fields for the contact. Fields include:
**Mobile 1/Home/Work/E-mail 1/Group/Picture/Ringtone/
Mobile 2/Fax/E-mail 2**
If entering information in a phone number field, press the Right Soft Key  [Options] to select one of the following options:
1. Set Speed Dial/2. Set As Default/3. Add Pause
4. Press the OK Key  [SAVE].

 For additional details on how to add a new contact, see [page 28](#).

CONTACT LIST



You can review all the entries stored in your Contact List or quickly find an entry by entering a name or its character string.

1. From standby mode, press the OK Key  [OK] to unlock the keypad, then press the OK Key  [MENU], then slide out the QWERTY keyboard, and press **2. Contact List**. Or, press the Right Soft Key  [Contacts]. The list of names in your contacts is displayed alphabetically.
2. Enter a name or part of a name in the Go to Field at the bottom of the screen or press the Directional Key  up or down to scroll through your Contact List.
3. To edit the entry, press the Left Soft Key  [Edit]. To view contact details, press the OK Key  [VIEW].
 - By pressing the Right Soft Key  [Options], you can choose from the following:
 - 1. New Contact:** To add a New Contact.
 - 2. Erase:** To delete a contact.
 - 3. New TXT Message:** To create a TXT message.
 - 4. New Picture Message:** To create a Picture message.
 - 5. New Voice Message:** To create a Voice message.

6. Set As ICE Contact: To set as emergency number.

7. Call: To call the contact.





8. Erase All Contacts: To delete all contact list.

4. To call the selected number, press the Right Soft Key  [Options] and then select **"7. Call"** or press the SEND Key .







GROUPS

Groups allows you to classify phone entries into groups with up to 10 numbers in each group. The default groups include No Group, Family and Work and they cannot be erased or renamed.





TO ADD NEW GROUP

1. From standby mode, press the OK Key  [OK] to unlock the keypad, then press the OK Key  [MENU], then slide out the QWERTY keyboard, and press **3. Groups**.
2. Press the Left Soft Key  [New].
3. Enter a new group name, then press the OK Key  [SAVE].

TO ASSIGN PHONE NUMBER TO GROUP





1. From standby mode, press the OK Key  [OK] to unlock the keypad, then press the OK Key  [MENU], then slide out the QWERTY keyboard, and press **3. Groups**.
2. Press the Directional Key  up or down to select the group where you want to add the contact, and then press the Right Soft Key  [Options].
3. Select **"Add"**.
4. Your contact entries will be displayed in alphabetical order. Select the contact you want to add then press the OK Key  [MARK].
5. Press the Left Soft Key  [Done]. "CONTACT ADDED TO [GROUP NAME]" will be displayed.

TO CHANGE GROUP NAME



1. From standby mode, press the OK Key  [OK] to unlock the keypad, then press the OK Key  [MENU], then slide out the QWERTY keyboard, and press **3. Groups**.
2. Press the Directional Key  up or down to select the group you want to rename then press the Right Soft Key  [Options].





3. Select "Rename".
4. Enter the new group name, then press the OK Key  [SAVE].

ERASE GROUP





1. From standby mode, press the OK Key  [OK] to unlock the keypad, then press the OK Key  [MENU], then slide out the QWERTY keyboard, and press 3. Groups.
2. Press the Directional Key  up or down to select the existing group name that you want to erase, and then press the Right Soft Key  [Options].
3. Select "Erase". "ERASE GROUP?" will appear on the screen.
4. Press the OK Key  [OK] to select "Yes". A confirmation message appears.











TO SEND A TXT MESSAGE TO A GROUP

1. From standby mode, press the OK Key  [OK] to unlock the keypad, then press the OK Key  [MENU], then slide out the QWERTY keyboard, and press 3. Groups.

2. Press the Directional Key  up or down to select the group you want to send a message to then press the Right Soft Key  [Options].
3. Press "1. New TXT Message".
4. Input your message in the Text Field and then press the Right Soft Key  [Options] to select "Save As Draft", "Add", "Edit Text Format", "Priority Level" and "Cancel Message".
5. To send the TXT message, press the OK Key  [SEND] or press the SEND Key .



TO SEND A PICTURE MESSAGE TO A GROUP

1. From standby mode, press the OK Key  [OK] to unlock the keypad, then press the OK Key  [MENU], then slide out the QWERTY keyboard, and press 3. Groups.
2. Press the Directional Key  up or down to select the group you want to send a message to then press the Right Soft Key  [Options].
3. Press "2. New Picture Message".









4. Under "Text", input your message and then press the Directional Key  down.
5. Under "Picture", press the Left Soft Key  [My Pics] to select the picture you would like to send then press the OK Key  [OK].
6. Under "Sound", press the Left Soft Key  [Sounds] to select the sound you would like to send then press the OK Key  [OK].
7. Under "Subject", input a subject and then press the Directional Key  down.
8. Under "Name Card", you can insert your name card. Press the Left Soft Key  [Add] select "1. My Name Card" or "2. Contacts" then press the OK Key  [OK]. Select the card you'd like to send then press the OK Key  [OK].
9. Press the Right Soft Key  [Options] to select "Preview", "Save As Draft", "Add Quick Text", "Add Slide", "Priority Level", "Remove Picture", "Remove Slide", "Remove Sound", "Remove Name Card" or "Cancel Message".







These options will vary depending on the message contents chosen.

10. To send the Picture Message, press the OK Key  [SEND] or press the SEND Key .

TO SEND A VOICE MESSAGE TO A GROUP

1. From standby mode, press the OK Key  [OK] to unlock the keypad, then press the OK Key  [MENU], then slide out the QWERTY keyboard, and press 3. Groups.
2. Press the Directional Key  up or down to select the group you want to send a voice message to then press the Right Soft Key  [Options].
3. Press "3. New Voice Message".
4. To record a new Voice Memo, press the OK Key  [OK] to start recording, then press the OK Key  [STOP] again to save the voice memo.
5. Under "Voice", your recorded file name will appear. Press the Directional Key  down.
6. Under "Text", input your message and then press the Directional Key  down.

- Under "Subject", input a subject and then press the Directional Key  down.
- Under "Name Card", you can insert your name card. Press the Left Soft Key  [Add], select "1. My Name Card" or "2. Contacts" then press the OK Key  [OK]. Select the card you'd like to send then press the OK Key  [OK].
- Press the Right Soft Key  [Options] to select "Review", "Save As Draft", "Add Quick Text", "Priority Level", "Remove Recording", "Remove Name Card" or "Cancel Message".

 These options will vary depending on the message contents chosen.









- To send the Voice Message, press the OK Key  [SEND] or press the SEND Key .

SPEED DIALS

In idle mode, calls can be placed to numbers stored in speed dial by sliding out the QWERTY keyboard, and pressing & holding the location number on the keypad. For a 2-digit location number, press the first number and then press and hold the second number. For a 3-digit location number, press the first number, and second numbers and then press and hold the third number. Speed Dial 1 is assigned to Voice Mail and cannot be changed. Speed Dial entries 97(#BAL),

98(#MIN), 99(#PMT) and 411 (Directory Assistance) are already assigned to Verizon Wireless Account Information.





- **#BAL:** #BAL is a VZW Customer Service VRU number (Free call) that provides customers information about their Verizon Wireless billing balance.
- **#MIN:** #MIN is a VZW Customer Service VRU number (Free call) that provides customers information about their Verizon Wireless usage.
- **#PMT:** #PMT is a VZW Customer Service VRU number (Free call) that allows a user to make a bill payment, either with a payment option they have already set up, or using a new, one time payment option.
- **411:** 411 is a Directory Assistance number.

- From standby mode, press the OK Key  [OK] to unlock the keypad, then press the OK Key  [MENU], then slide out the QWERTY keyboard, and press 4. **Speed Dials.**
- Press the Directional Key  up or down to highlight the Speed Dial position, or enter the Speed Dial digit, then press the OK Key  [SET].
- Press the Directional Key  up or down to highlight the Contact then press the OK Key  [OK].
- Press the Directional Key  up or down to highlight the number you wish to select then press the OK Key  [OK].
- Press the Directional Key  up or down to select "Yes".

- Press the OK Key  [OK]. A confirmation message appears.

 "Unassigned" appears if the location is available.

TO ERASE A SAVED SPEED DIAL

- From standby mode, press the OK Key  [OK] to unlock the keypad, then press the OK Key  [MENU], then slide out the QWERTY keyboard, and press 4. **Speed Dials.**
- Press the Directional Key  up or down to select the Speed Dial entry you want to erase.
- Press the Right Soft Key  [Remove].
- Press the OK Key  [OK] to select "Yes."
- A confirmation window appears.







IN CASE OF EMERGENCY

Your phone has a special menu to organize your emergency contacts and personal information.



TO ASSIGN EMERGENCY CONTACTS

Follow the procedures below to register a Contact to be contacted in case of emergency, or to register a medical record number or other personal info.

To register up to three different Contacts to ICE:





- From standby mode, press the OK Key  [OK] to unlock the keypad, then press the OK Key  [MENU], then slide out the QWERTY keyboard, and press 5. **In Case of Emergency.**
- Press the Directional Key  up or down to select "Contact 1", "Contact 2", or "Contact 3", and then press the OK Key  [ADD].
- When selecting from the Contacts List, press "1. From Contacts", press the Directional Key  up or down to select the Contact entry, and then press the OK Key  [OK]. When adding a new Contact, press "2. New Contact", enter the info, and then press the OK Key  [SAVE].
- The Contact name will be displayed in place of "Contact 1", "Contact 2", or "Contact 3".

TO RE-ASSIGN EMERGENCY CONTACTS





- From standby mode, press the OK Key  [OK] to unlock the keypad, then press the OK Key  [MENU], then slide out the QWERTY keyboard, and press 5. **In Case of Emergency.**
- Select the contact you want to re-assign then press the Right Soft Key  [Options].

3. Select "1. Re-assign", then select "1. From Contacts" to select a contact from your Contact List, or "2. New Contact" to enter a new contact.
4. Press the OK Key  [OK]. A confirmation window appears.

TO ERASE ASSIGNED EMERGENCY CONTACTS







1. From standby mode, press the OK Key  [OK] to unlock the keypad, then press the OK Key  [MENU], then slide out the QWERTY keyboard, and press 5. In Case of Emergency.
2. Select the contact you want to erase then press the Right Soft Key  [Options].
3. Select "2. Unassign". Press the OK Key  [OK].
4. Press the OK Key  [OK] to select "Yes". A confirmation window appears.

TO CALL AN ASSIGNED EMERGENCY CONTACT

1. From standby mode, press the OK Key  [OK] to unlock the keypad, then press the OK Key  [MENU], then slide out the QWERTY keyboard, and press 5. In Case of Emergency.
2. Select the contact you want to call then press the Left Soft Key  [Call] or press the SEND Key .







TO ADD PERSONAL INFO

To store a Medical Record Number or other information that may be useful in case of an emergency:





1. From standby mode, press the OK Key  [OK] to unlock the keypad, then press the OK Key  [MENU], then slide out the QWERTY keyboard, and press 5. In Case of Emergency.
2. Press the Directional Key  up or down to select "Personal Info" and then press the OK Key  [VIEW].
3. Press the Directional Key  up or down to select "Note 1", "Note 2" or "Note 3" and then press the OK Key  [ADD].
4. Enter the information and then press the OK Key  [SAVE].



5. The information you enter now appears in place of "Note 1", "Note 2" or "Note 3".

TO EDIT SAVED PERSONAL INFO

1. From standby mode, press the OK Key  [OK] to unlock the keypad, then press the OK Key  [MENU], then slide out the QWERTY keyboard, and press 5. In Case of Emergency.
2. Press the Directional Key  up or down to select "Personal Info" and then press the OK Key  [VIEW].
3. Select the Note you want to edit then press the OK Key  [VIEW].
4. Press the OK Key  [EDIT]. Edit the Note then press the OK Key  [SAVE].

TO ERASE SAVED PERSONAL INFO





1. From standby mode, press the OK Key  [OK] to unlock the keypad, then press the OK Key  [MENU], then slide out the QWERTY keyboard, and press 5. In Case of Emergency.
2. Press the Directional Key  up or down to select "Personal Info" and then press the OK Key  [VIEW].

3. Select the Note you want to erase then press the Right Soft Key  [Erase].
4. Press the OK Key  [OK] to select "Yes". A confirmation window appears.





MY NAME CARD

A Name Card with the handset's mobile number automatically appears.

EDIT MY NAME CARD

1. From standby mode, press the OK Key  [OK] to unlock the keypad, then press the OK Key  [MENU], then slide out the QWERTY keyboard, and press 6. My Name Card.
2. Press the Left Soft Key  [Edit].
3. Edit the "My Name Card" options then press the OK Key  [SAVE] to save your changes.



SEND MY NAME CARD

1. From standby mode, press the OK Key  [OK] to unlock the keypad, then press the OK Key  [MENU], then slide out the QWERTY keyboard, and press **6. My Name Card**.
2. Press the Right Soft Key  [Send].
3. Select **“1. TXT Message”, “2. Picture Message” or “3. Voice Message”**.
4. Enter the recipient’s contact information then press the OK Key  [OK].
5. Enter your message in the Text Field and then press the OK Key  [SEND].

RECENT CALLS









The Recent Calls menu is a list of the last phone numbers or Contact entries for calls you placed, accepted, missed, or blocked. It is continually updated as new numbers are added to the beginning of the list and the oldest entries are removed from the bottom of the list.

ACCESS AND OPTIONS

1. From standby mode, press the OK Key  [OK] to unlock the keypad, then press the OK Key  [MENU].
2. Press the Directional Key  right once for **“RECENT CALLS”**.
3. Select a submenu.
 1. Missed
 2. Received
 3. Dialed
 4. All
 5. View Timers

MISSED

Displays information about the 90 most recently missed calls. Place a call to a missed call by simply pressing the SEND Key .









1. From standby mode, press the OK Key  [OK] to unlock the keypad, then press the OK Key  [MENU], the Directional Key  right once for **RECENT CALLS**, then slide out the QWERTY keyboard, and press **1. Missed**.
2. Press the Directional Key  up or down to highlight an entry, then:
 - Press the OK Key  [OPEN] to view the entry.
 - Press the Send Key  to place a call to the number.
 - Press the Right Soft Key  [Options] to select:
 - Save to Contacts:** To store the phone number in your Contacts.
 - Erase:** To erase a call listing.
 - Lock/Unlock:** To lock or unlock a call listing.
 - Erase All:** To erase all Missed Call entries.
 - View Timers:** To display usage time.
 - Press the Left Soft Key  [Message] to select:
 - TXT Message:** To send a TXT message to the contact.
 - Picture Message:** To send a Picture message to the contact.
 - Voice Message:** To send a Voice message to the contact.



After 90 missed calls, the oldest call will automatically be erased from the history.

RECEIVED









Displays information about the 90 most recently received calls. Place a call to a received call by simply pressing the SEND Key .

- From standby mode, press the OK Key  [OK] to unlock the keypad, then press the OK Key  [MENU], the Directional Key  right once for **RECENT CALLS**, then slide out the QWERTY keyboard, and press **2. Received**.
- Press the Directional Key  up or down to highlight an entry, then:
 - Press the OK Key  [OPEN] to view the entry.
 - Press the Send Key  to place a call to the number.
 - Press the Right Soft Key  [Options] to select:
 - Save to Contacts:** To store the phone number in your Contacts.
 - Erase:** To erase a call listing.
 - Lock/Unlock:** To lock or unlock a call listing.
 - Erase All:** To erase all Received Call entries.
 - View Timers:** To display usage time.
 - Press the Left Soft Key  [Message] to select:
 - TXT Message:** To send a TXT message to the contact.
 - Picture Message:** To send a Picture message to the contact.
 - Voice Message:** To send a Voice message to the contact.

 After 90 received calls, the oldest call will automatically be erased from the history.

DIALED









Displays information about the 90 most recently dialed numbers. Place a call to a dialed call by simply pressing the SEND Key .

- From standby mode, press the OK Key  [OK] to unlock the keypad, then press the OK Key  [MENU], the Directional Key  right once for **RECENT CALLS**, then slide out the QWERTY keyboard, and press **3. Dialed**.
- Press the Directional Key  up or down to highlight an entry, then:
 - Press the OK Key  [OPEN] to view the entry.
 - Press the Send Key  to place a call to the number.
 - Press the Right Soft Key  [Options] to select:
 - Save to Contacts:** To store the phone number in your Contacts.
 - Erase:** To erase a call listing.
 - Lock/Unlock:** To lock or unlock a call listing.
 - Erase All:** To erase all Dialed Call entries.
 - View Timers:** To display usage time.
 - Press the Left Soft Key  [Message] to select:
 - TXT Message:** To send a TXT message to the contact.
 - Picture Message:** To send a Picture message to the contact.
 - Voice Message:** To send a Voice message to the contact.

 After 90 dialed calls, the oldest call will automatically be erased from the history.

ALL

Displays information about the most recently received, dialed and missed calls.

- From standby mode, press the OK Key  [OK] to unlock the keypad, then press the OK Key  [MENU], the Directional Key  right once for **RECENT CALLS**, then slide out the QWERTY keyboard, and press **4. All**.
- Press the Directional Key  up or down to highlight an entry, then:
 - Press the OK Key  [OPEN] to view the entry.
 - Press the Send Key  to place a call to the number.
 - Press the Right Soft Key  [Options] to select:
 - Save to Contacts:** To store the phone number in your Contacts.
 - Erase:** To erase a call listing.
 - Lock/Unlock:** To lock or unlock a call listing.
 - Erase All:** To erase all All Call entries.
 - View Timers:** To display usage time.
 - Press the Left Soft Key  [Message] to select:
 - TXT Message:** To send a TXT message to the contact.
 - Picture Message:** To send a Picture message to the contact.
 - Voice Message:** To send a Voice message to the contact.

 After the 270 received, dialed or missed calls, the oldest call will automatically be erased from the history.

 **Shortcut:** To view a quick list of all your calls, press the Send Key  from standby mode.

BLOCKED



This menu appears only when "Incoming Call Restriction" is set.

- From standby mode, press the OK Key  [OK] to unlock the keypad, then press the OK Key  [MENU], the Directional Key  right once for **RECENT CALLS**, then **Blocked Calls**.
- Press the Directional Key  up or down to highlight an entry, then:
 - Press the OK Key  [OPEN] to view the entry.
 - Press the Send Key  to place a call to the number.
 - Press the Right Soft Key  [Options] to select:
 - Save to Contacts:** To store the phone number in your Contacts.
 - Erase:** To erase a call listing.
 - Lock/Unlock:** To lock or unlock a call listing.
 - Erase All:** To erase all Blocked Call entries.
 - View Timers:** To display usage time.
 - Press the Left Soft Key  [Message] to select:
 - TXT Message:** To send a TXT message to the contact.
 - Picture Message:** To send a Picture message to the contact.
 - Voice Message:** To send a Voice message to the contact.

 After 90 blocked calls, the oldest call will automatically be erased from the history.
Please refer to [page 64](#) for more details on "Restrictions".

VIEW TIMERS

Checks the usage time and manages your calls within the limit you set. The 11 timers include (Last Call, All Calls, Received Calls, Dialed Calls, Roaming Calls, Transmit Data, Received Data, Total Data, Last Reset, Lifetime Calls, Lifetime Data Counter):

1. From standby mode, press the OK Key  [OK] to unlock the keypad, then press the OK Key  [MENU], the Directional Key  right once for **RECENT CALLS**, then slide out the QWERTY keyboard, and press **5. View Timers**.

2. Press the Directional Key  up or down to highlight a call list. Call timers include:

Last Call/All Calls/Received Calls/Dialed Calls/Roaming Calls/
Transmit Data/Received Data/Total Data/Last Reset/Lifetime Calls/
Lifetime Data Counter

- Press the Left Soft Key  [Reset] to reset highlighted timer.
- Press the Right Soft Key  [Reset All] to reset all timers.

BLUETOOTH MENU

Bluetooth technology connectivity enables wireless connections between electronic devices. If connected with a Bluetooth Handsfree device, you can use your phone more freely. Since devices with Bluetooth connectivity communicate using radio waves, your phone and the other device do not need to be in direct line-of-sight. The two devices only need to be within 10 meters (30 feet) of each other. The connection can be subject to interference from obstructions such as walls or other electronic devices.





This device is compliant with Bluetooth specification 2.0, supporting the following profiles: HSP V1.0 (headset profile), AVRCP V1.0 (stereo profile), and HFP V1.5 (handsfree car kit profile). To ensure interoperability between other devices supporting Bluetooth technology, use approved enhancements for this model. Check with the manufacturers of other devices to determine their compatibility with this phone. There may be restrictions on using Bluetooth technology in some locations. Check with your local authorities or Verizon Wireless. If you want more information on this function, visit the Bluetooth Technology organization Web site: <https://www.bluetooth.org/>.



Important: Features using Bluetooth technology, or allowing such features to run in the background while using other features, increase the demand on battery power and reduce the battery life.





BLUETOOTH ON/OFF





To toggle Bluetooth® power On/Off:

1. From standby mode, press the OK Key  [OK] to unlock the keypad, then press the OK Key  [MENU], the Directional Key  right twice for **SETTINGS & TOOLS**, then slide out the QWERTY keyboard, and press **3. Bluetooth Menu**.
2. Press the Left Soft Key  [Turn On/Turn Off]. A Confirmation window appears.

ADD NEW DEVICE

Pairing is the process that allows the handset to locate, establish and register a 1-to-1 connection with the target device.

1. Follow the Bluetooth® accessory instructions to set the device to pairing mode.
2. From standby mode, press the OK Key  [OK] to unlock the keypad, then press the OK Key  [MENU], the Directional Key  right twice for **SETTINGS & TOOLS**, then slide out the QWERTY keyboard, and press **3. Bluetooth Menu**. Press the OK Key  [OK] or select “1. Add New Devices”.



- If the Bluetooth® power is switched off, the following message will appear on the LCD screen: "TURN BLUETOOTH POWER ON?" Press the OK Key  [OK] to select "Yes".
- The handset will prompt you with the following message on the LCD screen: "PLACE DEVICE YOU ARE CONNECTING TO IN DISCOVERABLE MODE". Press the OK Key  [OK].
- The device will appear in the "ADD NEW DEVICE" menu. Press the Directional Key  up or down to select the device you wish to pair to, then press the OK Key  [PAIR].
- The handset will prompt you for the passkey. Consult the Bluetooth® accessory (sold separately) instructions for the appropriate passkey (typically "0000"—4 zeroes). Enter the passkey, then press the OK Key  [OK].

 You do not need to input the passkey for pairing when the passkey of the Bluetooth® Headset or hands-free kit is 0000.





- The handset will prompt you with the following message on the LCD screen: [Device Name] Before Connecting. If you would like to always confirm before connecting to the Bluetooth® device, select Always Ask, then press the OK Key  [OK]. Then the handset will prompt you with the message Connect to [Device Name].



Select "Yes", then press the OK Key  [OK]. If you do not wish to confirm every time before connecting to the Bluetooth® device, select Always Connect, then press the OK Key  [OK].

- Once connected, you will see the device listed in the Bluetooth Menu and the Bluetooth® device connected icon will appear at the top of the LCD screen when connected to the Bluetooth® device. You can also check out the connection with an Arrow icon on the Bluetooth Menu.

-  In the Bluetooth Menu, you can disconnect the connected device with an icon by pressing the OK Key  [Drop]. Conversely, you can reconnect by pressing the OK Key  [OK] again.
- When an audio device is connected, you can select another device and the connection is automatically transferred from that audio device to the other one.
- If multiple devices are displayed, select the devices you want to connect.

OPTIONS





- From standby mode, press the OK Key  [OK] to unlock the keypad, then press the OK Key  [MENU], the Directional Key  right twice for **SETTINGS & TOOLS**, then slide out the QWERTY keyboard, and press **3. Bluetooth Menu**.
- Press the Directional Key  up or down to select the paired device.

- Press the Right Soft Key  [Options].
- Press the Directional Key  up or down to select one of the following options, then press the OK Key  [OK].
 - Remove Device:** Removes a device from the pairing list.
 - Rename Device:** Renames a paired device.
 - Incoming Security:** Sets permissions for connecting an incoming device.
 - Service Discovery:** To search for the services that the selected device supports.
 - Device Info:** Displays device information.

SETTINGS





MY PHONE NAME

To edit the Bluetooth® name of your phone:

- From standby mode, press the OK Key  [OK] to unlock the keypad, then press the OK Key  [MENU], the Directional Key  right twice for **SETTINGS & TOOLS**, then slide out the QWERTY keyboard, and press **3. Bluetooth Menu**.
- Press the Right Soft Key  [Options].
- Press "**1. My Phone Name**".
- Use the numeric keypad to enter a new custom name.
- Press the OK Key  [OK] to save and exit.

DISCOVERY MODE

To set whether your device is able to be searched for by other Bluetooth® devices in the area:

- From standby mode, press the OK Key  [OK] to unlock the keypad, then press the OK Key  [MENU], the Directional Key  right twice for **SETTINGS & TOOLS**, then slide out the QWERTY keyboard, and press **3. Bluetooth Menu**.
- Press the Right Soft Key  [Options].
- Press "**2. Discovery Mode**".



 If Bluetooth power is not on, you will be prompted to turn it on in order to proceed.

- Press the Directional Key  up or down to select "On/Off", then press the OK Key  [OK].

SUPPORTED PROFILES







To view brief descriptions of the profiles supported by the phone:

- From standby mode, press the OK Key  [OK] to unlock the keypad, then press the OK Key  [MENU], the Directional Key  right twice for **SETTINGS & TOOLS**, then slide out the QWERTY keyboard, and press **3. Bluetooth Menu**.

2. Press the Right Soft Key  [Options].
3. Press "3. Supported Profiles".
4. Press the Directional Key  up or down to select one of the following profiles, and then press the OK Key  [VIEW].
Headset/Handsfree/Stereo

AUTO PAIR HANDSFREE



To set Auto Pair Handsfree On/Off:

1. From standby mode, press the OK Key  [OK] to unlock the keypad, then press the OK Key  [MENU], the Directional Key  right twice for **SETTINGS & TOOLS**, then slide out the QWERTY keyboard, and press 3. **Bluetooth Menu**.
2. Press the Right Soft Key  [Options].
3. Press "4. Auto Pair Handsfree".
4. Press the Directional Key  up or down to select "On/Off", then press the OK Key  [OK].







SOUNDS SETTINGS

CALL SOUNDS





To set ringtones for types of incoming calls:

1. From standby mode, press the OK Key  [OK] to unlock the keypad, then press the OK Key  [MENU], the Directional Key  right twice for **SETTINGS & TOOLS**, then slide out the QWERTY keyboard and press 4. **Sounds Settings, 1. Call Sounds**.

CALL RINGTONE







1. From standby mode, press the OK Key  [OK] to unlock the keypad, then press the OK Key  [MENU], the Directional Key  right twice for **SETTINGS & TOOLS**, then slide out the QWERTY keyboard and press 4. **Sounds Settings, 1. Call Sounds, 1. Call Ringtone**.
2. Press the Directional Key  up or down to select a ringtone, then press the OK Key  [OK] to save the sound. To play the ringtone, press the Left Soft Key  [Play].







CALL VIBRATE

1. From standby mode, press the OK Key  [OK] to unlock the keypad, then press the OK Key  [MENU], the Directional Key  right twice for **SETTINGS & TOOLS**, then slide out the QWERTY keyboard and press 4. **Sounds Settings, 1. Call Sounds, 2. Call Vibrate**.
2. Press the Directional Key  up or down to select "On/Off", then press the OK Key  [OK].





ALERT SOUNDS

To select the alert type for a new message:

1. From standby mode, press the OK Key  [OK] to unlock the keypad, then press the OK Key  [MENU], the Directional Key  right twice for **SETTINGS & TOOLS**, then slide out the QWERTY keyboard and press 4. **Sounds Settings, 2. Alert Sounds**.
2. Press the Directional Key  up or down to select "1. TXT Message", "2. Pic-Voice Message", "3. Voicemail" then press the OK Key  [OK].
3. Press the Directional Key  up or down to select "Tone", "Vibrate", "Reminder", then press the OK Key  [OK].





- **Tone:** Press the Directional Key  up or down to select a ringer, then press the OK Key  [OK]. To play the alert tone, press the Left Soft Key  [Play].
- **Vibrate:** Press the Directional Key  up or down to select "On/Off", then press the OK Key  [OK].
- **Reminder:** Press the Directional Key  up or down to select "Once", "Every 2 Minutes", "Every 15 Minutes", "Off", then press the OK Key  [OK].

EMERGENCY TONE

1. From standby mode, press the OK Key  [OK] to unlock the keypad, then press the OK Key  [MENU], the Directional Key  right twice for **SETTINGS & TOOLS**, then slide out the QWERTY keyboard and press 4. **Sounds Settings, 2. Alert Sounds, 4. Emergency Tone**.
2. Press the Directional Key  up or down to select one of the following settings, then press the OK Key  [OK].
Alert/Vibrate/Off





KEYPAD VOLUME

To set the keypad volume:

1. From standby mode, press the OK Key  [OK] to unlock the keypad, then press the OK Key  [MENU], the Directional Key  right twice for **SETTINGS & TOOLS**, then slide out the QWERTY keyboard and press **4. Sounds Settings, 3. Keypad Volume**.
2. Adjust the volume by pressing the Directional Key  up or down, then press the OK Key  [OK] to save the setting.

SERVICE ALERTS

To set any of the three Alert options to either On or Off:

1. From standby mode, press the OK Key  [OK] to unlock the keypad, then press the OK Key  [MENU], the Directional Key  right twice for **SETTINGS & TOOLS**, then slide out the QWERTY keyboard and press **4. Sounds Settings, 4. Service Alerts**.
2. Press the Directional Key  up or down to select one of the following options, then press the OK Key  [OK].

- **ERI:** The Enhanced Roaming Indicator (ERI) feature displays a text banner on the display screen informing the handset user of which systems the wireless device is using as compared to the service plan they purchased. The ERI Banner text changes to tell a customer if they are using the: "Verizon Wireless Network", "Extended Network" or "Roaming".





- **Minute Beep:** Alerts you every minute during a call.

- **Call Connect:** Alerts you when the call is connected.

3. Press the Directional Key  up or down to select "On/Off", then press the OK Key  [OK].





DEVICE CONNECT

Allows you to turn the Device Connect On or Off:

1. From standby mode, press the OK Key  [OK] to unlock the keypad, then press the OK Key  [MENU], the Directional Key  right twice for **SETTINGS & TOOLS**, then slide out the QWERTY keyboard and press **4. Sounds Settings, 5. Device Connect**.
2. Press the Directional Key  up or down to select "On/Off", then press the OK Key  [OK].





POWER ON/OFF

To set the phone to sound a tone when the phone is powered on/off:

1. From standby mode, press the OK Key  [OK] to unlock the keypad, then press the OK Key  [MENU], the Directional Key  right twice for **SETTINGS & TOOLS**, then slide out the QWERTY keyboard and press **4. Sounds Settings, 6. Power On/Off**.
2. Press "1. Power On" or "2. Power Off".
3. Press the Directional Key  up or down to select "On/Off", then press the OK Key  [OK].

OPEN/CLOSE SOUND

To set the phone to sound a tone when the phone Slide is Opened/Closed:

1. From standby mode, press the OK Key  [OK] to unlock the keypad, then press the OK Key  [MENU], the Directional Key  right twice for **SETTINGS & TOOLS**, then slide out the QWERTY keyboard and press **4. Sounds Settings, 7. Open/Close Sound**.
2. Press the Directional Key  up or down to select "On/Off", then press the OK Key  [OK].

DISPLAY SETTINGS





Allows you to customize the display.

BANNER

To set your Personal or ERI banner:





PERSONAL BANNER

The Personal Banner can be up to 16 characters and is displayed on your phone's screen in standby mode.

1. From standby mode, press the OK Key  [OK] to unlock the keypad, then press the OK Key  [MENU], the Directional Key  right twice for **SETTINGS & TOOLS**, then slide out the QWERTY keyboard and press **5. Display Settings, 1. Banner, 1. Personal Banner**.
2. Enter your banner text (up to 16 characters) then press the OK Key  [OK].





ERI BANNER

If you use ERI Service, ERI Text is shown on the sub banner.

1. From standby mode, press the OK Key  [OK] to unlock the keypad, then press the OK Key  [MENU], the Directional Key  right twice for **SETTINGS & TOOLS**, then slide out the QWERTY keyboard and press **5. Display Settings, 1. Banner, 2. ERI Banner**.
2. Press the Directional Key  up or down to select "On/Off", then press the OK Key  [OK].

BACKLIGHT

To set the duration for backlight illumination for the Main Screen and Keypad:







1. From standby mode, press the OK Key  [OK] to unlock the keypad, then press the OK Key  [MENU], the Directional Key  right twice for **SETTINGS & TOOLS**, then slide out the QWERTY keyboard and press **5. Display Settings, 2. Backlight**.
2. Press "1. Display" or "2. Keypad".
3. Press the Directional Key  up or down to select one of the following settings, then press the OK Key  [OK].
7 Seconds/15 Seconds/30 Seconds/Always On/Always Off



Even if "Always On" is selected for the Backlight setting, the backlight will turn off when the phone is closed.



WALLPAPER

To choose the kind of background to be displayed on the phone:

1. From standby mode, press the OK Key  [OK] to unlock the keypad, then press the OK Key  [MENU], the Directional Key  right twice for **SETTINGS & TOOLS**, then slide out the QWERTY keyboard and press **5. Display Settings, 3. Wallpaper**.
2. Select from the available screens, then press the OK Key  [OK]. To view the image, press the Left Soft Key  [View].
3. Press the Right Soft Key  [Get New], "1. Get New Applications" to download other available selections.

DISPLAY THEMES





To choose the background screen:

1. From standby mode, press the OK Key  [OK] to unlock the keypad, then press the OK Key  [MENU], the Directional Key  right twice for **SETTINGS & TOOLS**, then slide out the QWERTY keyboard and press **5. Display Settings, 4. Display Themes**.

2. Press the Directional Key  up or down to select one of the following settings, then press the OK Key  [SET].
Urban/Charming



MAIN MENU

To change Main Menu layout and type:

1. From standby mode, press the OK Key  [OK] to unlock the keypad, then press the OK Key  [MENU], the Directional Key  right twice for **SETTINGS & TOOLS**, then slide out the QWERTY keyboard and press **5. Display Settings, 5. Main Menu**.
2. Press the Directional Key  up or down to select one of the following layouts, and then press the OK Key  [OK].
Tab/List/Grid

DIAL FONTS





To set the font size:

1. From standby mode, press the OK Key  [OK] to unlock the keypad, then press the OK Key  [MENU], the Directional Key  right twice for **SETTINGS & TOOLS**, then slide out the QWERTY keyboard and press **5. Display Settings, 6. Dial Fonts**.

2. Press the Directional Key  up or down to select one of the following settings, then press the OK Key  [OK].
Normal/Large Only

CLOCK FORMAT

To choose the kind of clock to be displayed on the LCD screen:

1. From standby mode, press the OK Key  [OK] to unlock the keypad, then press the OK Key  [MENU], the Directional Key  right twice for **SETTINGS & TOOLS**, then slide out the QWERTY keyboard and press **5. Display Settings, 7. Clock Format**.
2. Press the Directional Key  up or down to select one of the following settings, then press the OK Key  [OK].
Analog/Large Analog/Digital 12/Large Digital 12/Digital 24/Large Digital 24/Off







"Digital 12" is the default setting for this device.

PHONE SETTINGS

AIRPLANE MODE



In Airplane Mode, all menu functions can be accessed except making calls, receiving calls, data connection and Bluetooth®. Activating Airplane Mode will disable all wireless communications. In the Airplane Mode, services that support Location On functions like Chaperone are temporarily disabled.

1. From standby mode, press the OK Key  [OK] to unlock the keypad, then press the OK Key  [MENU], the Directional Key  right twice for **SETTINGS & TOOLS**, then slide out the QWERTY keyboard and press **6. Phone Settings, 1. Airplane Mode**.
2. Press the Directional Key  up or down to select "On/Off", then press the OK Key  [OK].









SET SHORTCUTS

Your phone offers you the option of assigning a shortcut key (Directional Key left, right, up, and down) to a favorite or often-used function. In addition, choose menu settings for each of the shortcut options under **Set My Shortcuts** (Directional Key right).

 In idle mode, press the Directional Key  right to connect **Set Shortcuts** menu and press the Left Soft Key  [Settings].







1. From standby mode, press the OK Key  [OK] to unlock the keypad, then press the OK Key  [MENU], the Directional Key  right twice for **SETTINGS & TOOLS**, then slide out the QWERTY keyboard and press **6. Phone Settings, 2. Set Shortcuts, 1. Set My Shortcuts**.
2. Press the Directional Key  up or down to select "Shortcut 1", "Shortcut 2", "Shortcut 3", or "Shortcut 4", and then press the OK Key  [SET].
3. Press the Directional Key  up or down to select one of the following functions, then press the OK Key  [OK].
 - Alarm Clock / • Browse & Download / • Bluetooth Menu / • Bluetooth on/off / • Calculator / • Calendar / • Call Settings / • Chat / • Display Settings / • Extras / • Games / • Get New Extra / • Get New Game / • Get New Pictures / • Get New Ringtones / • Get New Browse & Download / • Media Center / • Messaging Inbox / • Mobile IM / • Mobile Web / • Mobile Web Mail / • Music & Tones / • My Music / • My Pictures / • My Ringtones / • My Sounds / • My Verizon / • New Contact / • New TXT Message / • New Picture Message / • Phone Settings / • Pictures / • Online Album / • Play All Songs / • Settings & Tools / • Sounds Settings / • Sync Music / • Tools / • Download Application Alphabet

 The "Download Application Alphabet" option only appears when you have downloaded Brew Applications.

 In standby mode, pressing the Directional Key  right will display the "My Shortcuts" screen. On the "My Shortcuts" screen, you can press the Directional Key  up or down to select a function and then press the OK Key  [OK] to access the function. On the "My Shortcuts" screen, you can relocate a function by pressing the Right Soft Key  [Move], pressing the Directional Key  up or down, and then pressing the OK Key  [SAVE]. Or you can press the Left Soft Key  [Settings] to Set My Shortcuts or Set Directional Keys.







RESETTING MY SHORTCUTS

To return My Shortcuts to their original defaults:

1. From standby mode, press the OK Key  [OK] to unlock the keypad, then press the OK Key  [MENU], the Directional Key  right twice for **SETTINGS & TOOLS**, then slide out the QWERTY keyboard and press **6. Phone Settings, 2. Set Shortcuts, 1. Set My Shortcuts**.
2. Press the Directional Key  up or down to select "Shortcut 1", "Shortcut 2", "Shortcut 3", or "Shortcut 4", and then press the Right Soft Key  [Options].
3. Press "1. Reset Shortcut (1, 2, 3, or 4)", or "2. Reset My Shortcuts".
4. Press the Directional Key  up or down to select "Yes", then press the OK Key  [OK].

SET DIRECTIONAL KEYS

In standby mode, you can specify the function that is accessed when you press the Directional Key  up, down or left.

1. From standby mode, press the OK Key  [OK] to unlock the keypad, then press the OK Key  [MENU], the Directional Key  right twice for **SETTINGS & TOOLS**, then slide out the QWERTY keyboard and press **6. Phone Settings, 2. Set Shortcuts, 2. Set Directional Keys**.
2. Press the Directional Key  up or down to select "UP Directional Key", "LEFT Directional Key", or "DOWN Directional Key", and then press the OK Key  [SET].
3. Press the Directional Key  up or down to select one of the following functions, and then press the OK Key  [OK].
 - Alarm Clock / • Browse & Download / • Bluetooth Menu / • Bluetooth on/off / • Calculator / • Calendar / • Call Settings / • Chat / • Display Settings / • Extras / • Games / • Get New Extra / • Get New Game / • Get New Pictures / • Get New Ringtones / • Get New Browse & Download / • Media Center / • Messaging Inbox / • Mobile IM / • Mobile Web / • Mobile Web Mail / • Music & Tones / • My Music / • My Pictures / • My Ringtones / • My Sounds / • My Verizon / • New Contact / • New TXT Message / • New Picture Message / • Phone Settings / • Pictures / • Online Album / • Play All Songs / • Settings & Tools / • Sounds Settings / • Sync Music /

• Tools / • Download Application Alphabet



The "Download Application Alphabet" option only appears when you have downloaded Brew Applications.

RESETTING THE DIRECTIONAL KEY SETTINGS

Use the following procedure to specify the default directional key settings.

1. From standby mode, press the OK Key [OK] to unlock the keypad, then press the OK Key [MENU], the Directional Key right twice for **SETTINGS & TOOLS**, then slide out the QWERTY keyboard and press **6. Phone Settings, 2. Set Shortcuts, 2. Set Directional Keys**.
2. Press the Directional Key up or down to select "UP Directional Key", "LEFT Directional Key", or "DOWN Directional Key", and then press the Right Soft Key [Options].
3. Press "1. Reset (UP, LEFT or DOWN) Key", or "2. Reset Directional Keys".
4. Press the Directional Key up or down to select "Yes", then press the OK Key [OK].

VOICE COMMANDS

You can use voice commands to control your device.

MODE

1. From standby mode, press the OK Key [OK] to unlock the keypad, then press the OK Key [MENU], the Directional Key right twice for **SETTINGS & TOOLS**, then slide out the QWERTY keyboard and press **6. Phone Settings, 3. Voice Commands**.
2. Press "1. Mode", then select one of the following:
 - **Prompts:** Reads out only the command prompts in voice command.
 - **Readout:** Reads out prompts, menus, outgoing contact name, status information, and confirming message recipient (contact name and type or number) when using the Send command.
 - **Tones Only:** Will only prompt the user with a tone (in place of the Readout prompt).



If you change the setting details in the phone's mode in Voice Commands, it will affect the mode in Sound (refer to [page 78](#)) or vice versa.

CALL ALERT

1. From standby mode, press the OK Key [OK] to unlock the keypad, then press the OK Key [MENU], the Directional Key right twice for **SETTINGS & TOOLS**, then slide out the QWERTY keyboard and press **6. Phone Settings, 3. Voice Commands**.

2. Press "2. Call Alert", then select one of the following:
 - **Ring Only:** Deactivate Caller ID. You can hear ringtone only.
 - **Caller ID + Ring:** Playback the Caller ID once and then you will hear ringtone.
 - **Name Repeat:** Activate Caller ID. You will hear the caller's details repeatedly.



For more information about the enhanced voice commands supported by your device, see "Voice Tools". Please refer to [page 74](#) for more details.

LANGUAGE

To set the bilingual feature to either English or Spanish:

1. From standby mode, press the OK Key [OK] to unlock the keypad, then press the OK Key [MENU], the Directional Key right twice for **SETTINGS & TOOLS**, then slide out the QWERTY keyboard and press **6. Phone Settings, 4. Language**.
2. Press the Directional Key up or down to select one of the following settings, then press the OK Key [OK].
English/Español

LOCATION

1. From standby mode, press the OK Key [OK] to unlock the keypad, then press the OK Key [MENU], the Directional Key right twice for **SETTINGS & TOOLS**, then slide out the QWERTY keyboard and press **6. Phone Settings, 5. Location**.
2. Press the Directional Key up or down to select one of the following settings, then press the OK Key [OK].
 - **Location On:** Your location is now available to the network.
 - **E911 Only:** Your location will be hidden from the network and applications, except for 911.



When "Lock Setting" is selected for Location Settings under "Restrictions" on the Security Menu, you will need to enter a Lock Code. The default Lock Code is "0000".







SECURITY

The Security menu allows you to electronically secure the phone.

 The default lock code is the last 4 digits of your Mobile Telephone Number.

EDIT CODES

To set a new Lock Code:





1. From standby mode, press the OK Key  [OK] to unlock the keypad, then press the OK Key  [MENU], the Directional Key  right twice for **SETTINGS & TOOLS**, then slide out the QWERTY keyboard and press **6. Phone Settings, 6. Security**.
2. Enter the four-digit lock code, then press the OK Key  [OK].
3. Press **"1. Edit Codes"**.
4. Press the Directional Key  up or down to select one of the following settings, then press the OK Key  [OK].

- **Phone Only:** Allows you to edit the Lock Code for Security. (The default Lock Code is the last 4 digits of your Mobile Telephone Number.)
- **Calls & Services:** Allows you to edit the Lock Code for Restrictions. (The default Lock Code is "0000".)

5. If **"Phone Only"** is selected, enter the new four-digit code in the **"Enter New Code"** field. Enter the new four-digit code again in the **"Re-enter New Code"** field.
6. If **"Calls & Services"** is selected, enter the current lock code in the **"Enter Current Code"** field. Enter the new four-digit code in the **"Enter New Code"** field. Enter the new four-digit code again.
7. Press the OK Key  [OK].

RESTRICTIONS

Use the following procedure to configure Location Setting, Calls and Messages restrictions.





1. From standby mode, press the OK Key  [OK] to unlock the keypad, then press the OK Key  [MENU], the Directional Key  right twice for **SETTINGS & TOOLS**, then slide out the QWERTY keyboard and press **6. Phone Settings, 6. Security**.
2. Enter the four-digit Lock Code, then press the OK Key  [OK]. The default Lock Code is "0000".
3. Press **"2. Restrictions"**.
4. Enter the four-digit Lock Code again, then press the OK Key  [OK].

5. Select one of the following settings:

- **Location Setting:** **Unlock Setting/Lock Setting.**
- **Calls:** Incoming Calls/Outgoing Calls
For Incoming Calls, set **Allow All/Contacts Only/Block All.**
For Outgoing Calls, set **Allow All/Contacts Only/Block All.**
- **Messages:** Incoming Messages/Outgoing Messages
For Incoming Messages, set **Allow All/Block All.**
For Outgoing Messages, set **Allow All/Block All.**

PHONE LOCK SETTING

This setting specifies whether the phone should be locked whenever it is turned on. Lock Mode prevents the unauthorized use of your phone. Once the phone is locked, it is in restricted mode until the Lock Code is entered. You can still make emergency calls. You can modify the Lock Code using the new Lock code within the Security menu.







1. From standby mode, press the OK Key  [OK] to unlock the keypad, then press the OK Key  [MENU], the Directional Key  right twice for **SETTINGS & TOOLS**, then slide out the QWERTY keyboard and press **6. Phone Settings, 6. Security**.
2. Enter the four-digit Lock Code, then press the OK Key  [OK]. The default lock code is the last 4 digits of your Mobile Telephone Number.
3. Press **"3. Phone Lock Setting"**.

4. Press the Directional Key  up or down to select one of the following settings, then press the OK Key  [OK].

- **Unlocked:** Phone is unlocked.
- **On Power Up:** Phone will lock when it is turned on.









LOCK PHONE NOW

Lock the phone now.

1. From standby mode, press the OK Key  [OK] to unlock the keypad, then press the OK Key  [MENU], the Directional Key  right twice for **SETTINGS & TOOLS**, then slide out the QWERTY keyboard and press **6. Phone Settings, 6. Security**.
2. Enter the four-digit Lock Code, then press the OK Key  [OK]. The default Lock Code is the last 4 digits of your mobile telephone number.
3. Press **"4. Lock Phone Now"**.
4. To unlock the phone, in stanby mode, press the Right Soft Key  [Unlock] and enter the four-digit Lock Code, then press the OK Key  [OK].





RESTORE PHONE

To delete all User Data and restore all settings to their initial defaults:

1. From standby mode, press the OK Key  [OK] to unlock the keypad, then press the OK Key  [MENU], the Directional Key  right twice for **SETTINGS & TOOLS**, then slide out the QWERTY keyboard and press **6. Phone Settings, 6. Security**.
2. Enter the four-digit Lock Code, then press the OK Key  [OK].
3. Press **"5. Restore Phone"**.
4. After reading the warning message that appears, press the Directional Key  up or down to select **"Yes"**, and then press the OK Key  [OK].
5. After reading the message that appears, press the OK Key  [OK].
6. Enter the four-digit Lock Code, then press the OK Key  [OK]. The phone will turn off and then back on again automatically.

SYSTEM SELECT

You can set your phone to search or roam on another network when you are not in your home area. Leave this setting as default unless you want to alter the system selection as instructed by your service provider.

1. From standby mode, press the OK Key  [OK] to unlock the keypad, then press the OK Key  [MENU], the Directional Key  right twice for **SETTINGS & TOOLS**, then slide out the QWERTY keyboard and press **6. Phone Settings, 7. System Select**.
2. Press the Directional Key  up or down to select one of the following settings, then press the OK Key  [OK].
 - **Automatic B:** Scan radio channels based on the Automatic B setting.
 - **Automatic A:** Scan radio channels based on the Automatic A setting.
 - **Home Only:** Only within your home area or home affiliated area.



NAM SELECTION

Enables Auto NAM (Number Assignment Modules) or manually selects a NAM.







AUTO NAM

Automatically switches phone to proper NAM when you have multiple NAM registrations.

1. From standby mode, press the OK Key  [OK] to unlock the keypad, then press the OK Key  [MENU], the Directional Key  right twice for **SETTINGS & TOOLS**, then slide out the QWERTY keyboard and press **6. Phone Settings, 8. NAM Selection**.

2. Press the Directional Key  up or down to select **"1. Auto NAM"**, then press the OK Key  [OK].
3. Select **"On/Off"**, then press the OK Key  [OK].





CHANGE NAM

1. From standby mode, press the OK Key  [OK] to unlock the keypad, then press the OK Key  [MENU], the Directional Key  right twice for **SETTINGS & TOOLS**, then slide out the QWERTY keyboard and press **6. Phone Settings, 8. NAM Selection**.
2. Press the Directional Key  up or down to select **"2. Change NAM"**, then press the OK Key  [OK].
3. Select **"NAM 1 - VERIZON"** or **"NAM 2 - VERIZON"**, then press the OK Key  [OK].

CALL SETTINGS

ANSWER OPTIONS

To determine how to handle an answered call:

1. From standby mode, press the OK Key  [OK] to unlock the keypad, then press the OK Key  [MENU], the Directional Key  right twice for **SETTINGS & TOOLS**, then slide out the QWERTY keyboard and press **7. Call Settings, 1. Answer Options**.
2. Press the Directional Key  up or down to select one of the following settings, then press the OK Key  [MARK].
Slide Open/Any Key/Auto w/ Hands-free.



"Slide Open" is the default setting for this device.







3. Press the Left Soft Key  [Done].



- When the phone is closed, the Auto w/ Hands-free Mode will not function, except when connected to a headset.
- The Auto w/ Hands-free will function after about five seconds.
- Auto w/ Hands-free is available only when connected to a headset or hands-free device.
- The three functions can be used at the same time.
- To answer all incoming calls, press the SEND Key .

END CALL OPTIONS



To determine how to handle an end call:

1. From standby mode, press the OK Key  [OK] to unlock the keypad, then press the OK Key  [MENU], the Directional Key  right twice for **SETTINGS & TOOLS**, then slide out the QWERTY keyboard and press **7. Call Settings, 2. End Call Options**.
2. Press the Directional Key  up or down to select "Slide Close", then press the OK Key  [MARK].
3. Press the Left Soft Key  [Done].

 To end a call, press the END Key .

AUTO RETRY





To set the length of time the phone waits before automatically redialing a number when the attempted call fails:

1. From standby mode, press the OK Key  [OK] to unlock the keypad, then press the OK Key  [MENU], the Directional Key  right twice for **SETTINGS & TOOLS**, then slide out the QWERTY keyboard and press **7. Call Settings, 3. Auto Retry**.

2. Press the Directional Key  up or down to select the following settings, then press the OK Key  [OK].
10 Seconds/30 Seconds/60 Seconds/Off.





TTY MODE

You can attach a TTY device to your phone enabling you to communicate with parties also using a TTY device. A phone with TTY support is able to translate typed characters to voice. Voice can also be translated into characters and then displayed on the TTY.

1. From standby mode, press the OK Key  [OK] to unlock the keypad, then press the OK Key  [MENU], the Directional Key  right twice for **SETTINGS & TOOLS**, then slide out the QWERTY keyboard and press **7. Call Settings, 4. TTY Mode**.
2. Press the Directional Key  up or down to select one of the following settings, then press the OK Key  [OK].
TTY Full/TTY + Talk/TTY + Hear/TTY Off.

ONE TOUCH DIAL





To initiate a speed dial call by holding down the speed dial digit:

1. From standby mode, press the OK Key  [OK] to unlock the keypad, then press the OK Key  [MENU], the Directional Key  right twice for **SETTINGS & TOOLS**, then slide out the QWERTY keyboard and press **7. Call Settings, 5. One Touch Dial**.
2. Press the Directional Key  up or down to select "On/Off", then press the OK Key  [OK].

 If One Touch Dial is disabled, Speed Dial numbers designated in your Contacts will not function.





VOICE PRIVACY

To turn the voice privacy feature On or Off:

1. From standby mode, press the OK Key  [OK] to unlock the keypad, then press the OK Key  [MENU], the Directional Key  right twice for **SETTINGS & TOOLS**, then slide out the QWERTY keyboard and press **7. Call Settings, 6. Voice Privacy**.
2. Press the Directional Key  up or down to select "On/Off", then press the OK Key  [OK].

DTMF TONES



To set the Key Tone length and touch tone playback speed:

1. From standby mode, press the OK Key  [OK] to unlock the keypad, then press the OK Key  [MENU], the Directional Key  right twice for **SETTINGS & TOOLS**, then slide out the QWERTY keyboard and press **7. Call Settings, 7. DTMF Tones**.
2. Press the Directional Key  up or down to select one of the following settings, then press the OK Key  [OK].
 - **Normal:** Sends out a tone for a fixed period of time even if you continue to press the key.
 - **Long:** Sends out a continuous tone for the duration the key is pressed and held.

MEMORY

SAVE OPTIONS

To select whether to save to Phone Memory or to Card Memory when saving a file:

1. From standby mode, press the OK Key  [OK] to unlock the keypad, then press the OK Key  [MENU], the Directional Key  right twice for **SETTINGS & TOOLS**, then slide out the QWERTY keyboard and press **8. Memory, 1. Save Options**.

2. Press the Directional Key  up or down to select one of the following settings, and then press the OK Key  [OK].

[Pictures/Sounds](#)

3. Press the Directional Key  up or down to select one of the following settings, and then press the OK Key  [OK].





[Phone Memory/Card Memory](#)

PHONE MEMORY

Select this option to display Phone Memory information, and to delete or move files saved in Phone Memory.















PHONE MEMORY USAGE

To check the available Phone Memory capacity, used capacity, and total capacity:

1. From standby mode, press the OK Key  [OK] to unlock the keypad, then press the OK Key  [MENU], the Directional Key  right twice for **SETTINGS & TOOLS**, then slide out the QWERTY keyboard and press **8. Memory, 2. Phone Memory**.
2. Press **"1. Phone Memory Usage"**.
3. Press the OK Key  [OK] to return to the previous screen.

DELETING AND MOVING FILES

To delete files stored in Phone Memory, and to move files from Phone Memory to Card Memory:

1. From standby mode, press the OK Key  [OK] to unlock the keypad, then press the OK Key  [MENU], the Directional Key  right twice for **SETTINGS & TOOLS**, then slide out the QWERTY keyboard and press **8. Memory, 2. Phone Memory**.
2. Press the Directional Key  up or down to select one of the following settings, and then press the OK Key  [OK].
[My Pictures/My Music/My Sounds](#)
3. Press the Right Soft Key  [Options].
4. Press the Directional Key  up or down to select **"1. Erase"** if you want to delete a file or **"2. Move"** if you want to move a file to Card Memory, and then press the OK Key  [OK].
5. Press the Directional Key  up or down to select a file, press the OK Key  [MARK] or the Right Soft Key  [Mark All], and then press the Left Soft Key  [Done].
6. Press the Directional Key  up or down to select **"Yes"**, and then press the OK Key  [OK].



Do not remove the memory card from the phone while a file is being moved to Card Memory.

CARD MEMORY





Select this option to display Card Memory information, and to delete or move files saved in Card Memory.



Memory card must be inserted into the phone to perform these functions.















CARD MEMORY USAGE

To check the available Card Memory capacity, used capacity, and total capacity:

1. From standby mode, press the OK Key  [OK] to unlock the keypad, then press the OK Key  [MENU], the Directional Key  right twice for **SETTINGS & TOOLS**, then slide out the QWERTY keyboard and press **8. Memory, 3. Card Memory**.
2. Press **"1. Card Memory Usage"**.
3. Press the OK Key  [OK] to return to the previous screen.

DELETING AND MOVING FILES



To delete files stored in Card Memory, and to move files from Card Memory to Phone Memory:

1. From standby mode, press the OK Key  [OK] to unlock the keypad, then press the OK Key  [MENU], the Directional Key  right twice for **SETTINGS & TOOLS**, then slide out the QWERTY keyboard and press **8. Memory, 3. Card Memory**.
2. Press the Directional Key  up or down to select one of the following settings, and then press the OK Key  [OK].
[My Pictures/My Music/My Sounds](#)
3. Press the Right Soft Key  [Options].
4. Press the Directional Key  up or down to select **"1. Erase"** if you want to delete a file or **"2. Move"** if you want to move a file to Phone Memory, and then press the OK Key  [OK].
5. Press the Directional Key  up or down to select a file, press the OK Key  [MARK] or the Right Soft Key  [Mark All], and then press the Left Soft Key  [Done].
6. Press the Directional Key  up or down to select **"Yes"**, and then press the OK Key  [OK].



PHONE INFO

MY NUMBER

To view your phone number:

1. From standby mode, press the OK Key  [OK] to unlock the keypad, then press the OK Key  [MENU], the Directional Key  right twice for **SETTINGS & TOOLS**, then slide out the QWERTY keyboard and press **9. Phone Info, 1. My Number**.
2. The following information appears:
**Mobile Device Number (MDN)/Mobile Identifications Number (MIN)/
Other device information**





SW/HW VERSION

1. From standby mode, press the OK Key  [OK] to unlock the keypad, then press the OK Key  [MENU], the Directional Key  right twice for **SETTINGS & TOOLS**, then slide out the QWERTY keyboard and press **9. Phone Info, 2. SW/HW Version**.
2. Displays the Software Version/PRL Version/ERI Version/Browser Version/Media Center Version/MSUI Version/HW Version/MEID.

3. Press the OK Key  [OK] to return to the previous screen.

ICON GLOSSARY

To view all the icons and their meanings:

1. From standby mode, press the OK Key  [OK] to unlock the keypad, then press the OK Key  [MENU], the Directional Key  right twice for **SETTINGS & TOOLS**, then slide out the QWERTY keyboard and press **9. Phone Info, 3. Icon Glossary**.
2. Press the OK Key  [OK] to return to the previous screen.



Please refer to [page 10](#) for more details a list of "Display Indicators".

SOFTWARE UPDATE

The update phone firmware (software) option allows you to download and update the software in your phone automatically. Only the internal software is updated; no Contacts entries or other information saved to your phone will be deleted.

STATUS



Check the latest Software Download/Update status.

1. From standby mode, press the OK Key  [OK] to unlock the keypad, then press the OK Key  [MENU], the Directional Key  right twice for **SETTINGS & TOOLS**, then slide out the QWERTY keyboard and press **9. Phone Info, 4. Software Update**.

2. Select "**1. Status**".



CHECK NOW

To check Download Server for new Software updates:

1. From standby mode, press the OK Key  [OK] to unlock the keypad, then press the OK Key  [MENU], the Directional Key  right twice for **SETTINGS & TOOLS**, then slide out the QWERTY keyboard and press **9. Phone Info, 4. Software Update**.
2. Select "**2. Check Now**".

VOICE COMMANDS

Your phone is equipped with an AVR (Advanced Voice Recognition) feature. This feature allows you to make calls or use the phone's functions by simply using your voice. All you have to do is talk into the phone, and the phone will recognize your voice and complete tasks by itself.

1. To access Voice Commands from standby mode, press the OK Key  [OK] to unlock the keypad, then press the OK Key  [MENU], the Directional Key  right twice for **SETTINGS & TOOLS**, then slide out the QWERTY keyboard and press **2. Tools, 1. Voice Commands**.

 **Shortcut:** In idle mode, press and hold the CLR Key  to access the Voice Commands menu.

2. The phone displays the Command menu and prompts you to say the name of the command you want to use. To complete your task, simply follow the voice prompts. You can speak the name of the command after you hear a beep.

 You can hear a beep in the Tone Only Mode (Settings & Tools > Phone Settings > Voice Commands > Mode > Tones Only Mode) while you can see a prompt without a beep sound in the Prompt Mode or Readout Mode.

3. Select one of the following options by pressing the Directional Key  up or down, press the OK Key .

- Call <Name or #> / • Send <MSG Type> / • Go To <Shortcut> /
- Check <Item> / • Contact <Name> / • Play <Playlist> / • My Verizon / • Help

4. When it recognizes one of these commands, the phone launches the associated application. If the phone does not hear a command within approximately eight seconds, AVR mode will turn itself off.

CALL <NAME OR #>

Use the Call command to voice dial a name from your contact list or a phone number. When dialing a number, pronounce each digit, but do not pause noticeably between the digits.

1. You will hear "Please say a command" and the Voice Commands menu will be displayed.
2. If calling a contact from your list, say Call <Name>. Your phone will ask you to confirm the name you said. Say "Yes" if it was repeated correctly. That phone number will be dialed. If there is more than one number saved for that contact, you will be asked to confirm which number to dial.

Examples: - Call Tom Smith, - Call 617 555-1212, - Call Bob Carson's mobile, - Call Dee Harper at Home.

SEND <MSG TYPE>

Use the Send command to send a text or other type of message to a specified name or number.

1. You will hear "Please say a command" and the Voice Commands menu will be displayed.
2. Say "Send" followed immediately by one of the following items:
 - Text / • Picture

Examples: - Send Picture to Dee Harper's Mobile,
- Send Text Tom Smith.

GO TO <SHORTCUT>

Use the Go To command to open an application on your phone. You can say "Go To" by itself and be prompted to say the application name, or you can skip the prompt by saying "Go To" followed by the application name.

1. You will hear "Please say a command" and the Voice Commands menu will be displayed.
2. Say "Go To" followed immediately by one of the following items:
 - Contacts / • Recent Calls / • Messaging / • Media Center / • Settings & Tools /
 - Mobile Web / • My Music

CHECK <ITEM>

The Check command lets you check status information for your phone. You can say "Check" or "Check Status" to see and hear all status information.

1. You will hear "Please say a command" and the Voice Commands menu will be displayed.
2. Say "Check" followed immediately by one of the following items:
 - Status / • Voicemail / • Messages / • Missed Calls / • Time /
 - Signal Strength / • Battery / • Volume

CONTACTS <NAME>

Use the Lookup command to retrieve and display information for any name stored in your contact list.

1. You will hear "Please say a command" and the Voice Commands menu will be displayed.
2. Say "Lookup <Name>".

Examples: - Lookup Tom Jones.
3. The View Contact page will be displayed for that contact name.

PLAY <PLAYLIST>

Use the Play command to playback one of the playlists. Say "PLAY" followed by a playlist and your phone will playback the recognized playlist for you.

1. You will hear "Please say a command" and the Voice Commands menu will be displayed.
2. Say "Play <Playlist>".
Say "Play All Songs" (to playback all songs saved in your phone.)

MY VERIZON

1. You will hear "Please say a command" and the Voice Commands menu will be displayed.
2. Say "My Verizon".
3. Your phone will make a web connection.







HELP

1. You will hear "Please say a command" and the Voice Commands menu will be displayed.
2. Say "Help".
3. The Help guide will be displayed on your phone.

VOICE COMMANDS SETTINGS

DIGIT DIAL READOUT



The Digit Dial Readout setting controls if digits are read out when you type in a phone number with the keypad.

1. From standby mode, press the OK Key  [OK] to unlock the keypad, then press the OK Key  [MENU], the Directional Key  right twice for **SETTINGS & TOOLS**, then slide out the QWERTY keyboard and press **2. Tools, 1. Voice Commands**.
2. Press the Right Soft Key  [Settings], "1. Digit Dial Readout".
3. Select "On/Off" by pressing the Directional Key  up or down, then press the OK Key  [OK].

CONFIRMATION







When voice recognition is not confident it has recognized a name or number correctly, it will show you a list of up to three choices. You can control when choice lists appear.

1. From standby mode, press the OK Key  [OK] to unlock the keypad, then press the OK Key  [MENU], the Directional Key  right twice for **SETTINGS & TOOLS**, then slide out the QWERTY keyboard and press **2. Tools, 1. Voice Commands**.

2. Press the Right Soft Key  [Settings], "2. Confirmation".
3. Select "Automatic," "Always Confirm" or "Never Confirm" by pressing the Directional Key  up or down, then press the OK Key  [OK].







SENSITIVITY

The Sensitivity setting controls how the voice recognition software determines when a spoken word is a match. If you frequently experience the messages "Please Repeat..." or "No Match Found," adjust the sensitivity toward Reject Less. If you frequently experience false activations (when the phone recognizes a name you didn't say), adjust the sensitivity toward Most Sensitive.

1. From standby mode, press the OK Key  [OK] to unlock the keypad, then press the OK Key  [MENU], the Directional Key  right twice for **SETTINGS & TOOLS**, then slide out the QWERTY keyboard and press **2. Tools, 1. Voice Commands**.
2. Press the Right Soft Key  [Settings], "3. Sensitivity".
3. Select "Most Sensitive," "Recommended" or "Least Sensitive" by pressing the Directional Key  up or down, then press the OK Key  [OK].

ADAPTATION

Voice Command is speaker independent, which means that no training or adaptation is required. Some users with heavy accents or unusual voice characteristics may find difficulty in achieving high accuracy with speaker independent Voice Command, so the Adapt Voice feature allows users to dramatically improve the recognition accuracy through adaptation. Users who get acceptable recognition accuracy will find no additional benefit to performing the Adapt Voice adaptation.

1. From standby mode, press the OK Key  [OK] to unlock the keypad, then press the OK Key  [MENU], the Directional Key  right twice for **SETTINGS & TOOLS**, then slide out the QWERTY keyboard and press **2. Tools, 1. Voice Commands**.
2. Press the Right Soft Key  [Settings], "4. Adaptation".
3. Select "1. Adapt Voice" or "2. Reset Voice" by pressing the Directional Key  up or down, then press the OK Key  [OK].
 - **Adapt Voice:** Requires that you make recordings of your voice to customize the voice recognitions system. It will take a few minutes.
 - **Reset Voice:** Once you finish the adaptation process, you can reset the adaptation to factory default.
4. Wait for the beep, and then repeat the sentences using a normal tone of voice.









"Reset Voice" menu option only appears after you finish the "Adapt Voice" process.

- Repeat steps 1-4. When you are finished with a full session, you will reach a screen that reads "Adaptation Complete".







PROMPTS

Allows you to select the voice command system characteristics.





- From standby mode, press the OK Key  [OK] to unlock the keypad, then press the OK Key  [MENU], the Directional Key  right twice for **SETTINGS & TOOLS**, then slide out the QWERTY keyboard and press **2. Tools, 1. Voice Commands**.
- Press the Right Soft Key  [Settings], "**5. Prompts**".
- Select "**1. Mode**" or "**2. Audio playback**" by pressing the Directional Key  up or down, then press the OK Key  [OK].
 - Mode:** Select the voice command system mode from the following:
 - Prompts:** For handset to read out voice command prompts.
 - Readout:** For handset to read out prompts, dialing digits and menus.
 - Tones Only:** For handset to prompt you with a tone only.
 - Audio playback:** Allows audio playback to play through the speakerphone or through the earpiece. Select "**Automatic**", "**Speakerphone**" or "**Earpiece**" with the Directional Key  up or down.

CALL ALERT

Provides audible readout of the phone number and/or name (if in your contact list) of an incoming call.

- From standby mode, press the OK Key  [OK] to unlock the keypad, then press the OK Key  [MENU], the Directional Key  right twice for **SETTINGS & TOOLS**, then slide out the QWERTY keyboard and press **2. Tools, 1. Voice Commands**.
- Press the Right Soft Key  [Settings], "**6. Call Alert**".
- Select "**Ring Only**", "**Caller ID + Ring**" or "**Name Repeat**" by pressing the Directional Key  up or down, then press the OK Key  [OK].









ABOUT











- From standby mode, press the OK Key  [OK] to unlock the keypad, then press the OK Key  [MENU], the Directional Key  right twice for **SETTINGS & TOOLS**, then slide out the QWERTY keyboard and press **2. Tools, 1. Voice Commands**.
- Press the Right Soft Key  [Settings], "**7. About**".
- The VoiceSignal version appears.
- To return to the previous screen, then press the OK Key  [OK].

CALCULATOR

The Calculator allows you to perform simple mathematical calculations.

To access the calculator:



- From standby mode, press the OK Key  [OK] to unlock the keypad, then press the OK Key  [MENU], the Directional Key  right twice for **SETTINGS & TOOLS**, then slide out the QWERTY keyboard and press **2. Tools, 2. Calculator**.
- Follow the instructions below to calculate $8 \times 6 \div 4 - 2.5 = 9.5$.
 - Input 8 and then press the Directional Key  right.
 - Input 6 and then press the Directional Key  left.
 - Input 4 and then press the Directional Key  down.
 - Input 2 and then press the  to input (.).
 - Press 5.
 - Then press the OK Key  and you will see the answer (9.5).
- To reset, press the Left Soft Key  [Clear].

-  Directional Key  right : X, Directional Key  down : -, Directional Key  left : \div , Directional Key  up : +, * Key  : \times , Left Soft Key  : Clear, OK Key  : =.
- To change the displayed number from positive (+) to negative (-) and vice versa, press # Key .
- Press the Right Soft Key  [Operator] to use parenthesis "1. (, "2.)" and "3. Exponent".



CALENDAR

The Calendar tool provides easy and convenient access to your schedule.

Simply store your appointments and your phone will alert you to them.

- From standby mode, press the OK Key  [OK] to unlock the keypad, then press the OK Key  [MENU], the Directional Key  right twice for **SETTINGS & TOOLS**, then slide out the QWERTY keyboard and press **2. Tools, 3. Calendar**.

 **Shortcut:** In idle mode, press the Directional Key  down to access Calendar.

- Press the Directional Key  up, down, left or right to highlight the scheduled day.
- Press the Left Soft Key  [Add].
- The Appointment field is highlighted. Enter the name of the event. Press the Directional Key  down to set the other fields for the event:

APPOINTMENT

Use the keypad to enter an appointment in your schedule.

START TIME

Use the keypad to set a start time and press the Left Soft Key  for "am/pm".





END TIME

Use the keypad to set an end time and press the Left Soft Key  for "am/pm".

START DATE

Use the keypad to change or enter the start date.

RECURRENCE

Press the Directional Key  left or right to set the recurrence of the event (*Daily, Weekly, Monthly, Yearly*). For each recurrence setting, press the Directional Key  down to set the "By Count" field. For "Daily", set the number of days. For "Weekly", you can press the Directional Key  left or right to select "By Count" or "By Day". Then press the Directional Key  down again to make the setting - for "By Count", enter the number of weeks. For "By Day", press the Directional Key  left or right to select a day of the week. For "Monthly", set "By Count" the number of months, or press the

Directional Key  right to set "By Day/Month". For "Yearly", set "By Day/Month".

END DATE

Use the keypad to change or enter the end date.

TIME ZONES

If the Time Zone needs to be adjusted, press the Left Soft Key  [Set]. Press the Directional Key  up or down to select a new time zone then press the OK Key  [OK].

• Off / • EST / • EDT / • CST / • CDT / • MST / • MDT / • PST / • PDT / • AKST / • AKDT / • HAST / • HADT / • GMT/UTC

ALERT

Press the Left Soft Key  [Set] to select a new ringtone. Press the Directional Key  up or down to highlight a ringtone then press the OK Key  [OK]. Press the Left Soft Key  [Play] to preview a ringtone.

VIBRATE

Press the Directional Key  left or right to set "On/Off".





REMINDER

Press the Directional Key  left or right to select an alert time interval option.



• 0 Minute / • 5 Minutes / • 10 Minutes / • 15 Minutes





5. Press the OK Key  [SAVE] to save it. The date of the event will be marked on your calendar.

VIEW PLAN LIST









1. From standby mode, press the OK Key  [OK] to unlock the keypad, then press the OK Key  [MENU], the Directional Key  right twice for **SETTINGS & TOOLS**, then slide out the QWERTY keyboard and press **2. Tools, 3. Calendar**.
2. Press the Directional Key  up, down, left or right to choose the event then press the OK Key  [VIEW].

ERASE SAVED EVENT

1. From standby mode, press the OK Key  [OK] to unlock the keypad, then press the OK Key  [MENU], the Directional Key  right twice for **SETTINGS & TOOLS**, then slide out the QWERTY keyboard and press **2. Tools, 3. Calendar**.







2. Press the Directional Key  up, down, left or right to choose the event then press the OK Key  [VIEW].
3. Press the Left Soft Key  [Erase], then press the Directional Key  up or down to select "Yes", and then press the OK Key  [OK].

ERASE ALL PASSED EVENTS

1. From standby mode, press the OK Key  [OK] to unlock the keypad, then press the OK Key  [MENU], the Directional Key  right twice for **SETTINGS & TOOLS**, then slide out the QWERTY keyboard and press **2. Tools, 3. Calendar**.
2. Press the Directional Key  up, down, left or right to choose the event then press the OK Key  [VIEW].
3. Press the Right Soft Key  [Options], "6. Erase Passed", then press the Directional Key  up or down to select "Yes", then press the OK Key  [OK].

ALARM CLOCK

The Alarm Clock tool allows you to set up to three alarms. When you set an alarm, the current time is displayed at the top of the screen. When the alarm goes off, Alarm 1 (or 2 or 3, as applicable) will be displayed on the LCD screen and the alarm will sound.

1. From standby mode, press the OK Key  [OK] to unlock the keypad, then press the OK Key  [MENU], the Directional Key  right twice for **SETTINGS & TOOLS**, then slide out the QWERTY keyboard and press **2. Tools, 4. Alarm Clock**.
2. Press the Directional Key  up or down to highlight an Alarm (1, 2, or 3), then press the OK Key  [OK].
3. The setting field will be highlighted. Press the Directional Key  down to select alarm options.

ALARM

Press the Directional Key  left or right to select "On/Off".



TIME

Use the keypad to set a time for the alarm and press the Left Soft Key  for "am/pm".

FREQUENCY







Press the Directional Key  left or right to select a setting for the alarm (*Once, Daily, Mon - Fri, Weekends*).

RINGER







Press the Left Soft Key  [Set] to "1. Get New Ringtones" or select the alert tone you wish to set. Press the Left Soft Key  [Play] to preview a ringtone. Press the OK Key  [OK] to make your selection.

4. To save an alarm setting, press the OK Key  [SAVE].







TURN ON/OFF THE ALARM SETTING

1. From standby mode, press the OK Key  [OK] to unlock the keypad, then press the OK Key  [MENU], the Directional Key  right twice for **SETTINGS & TOOLS**, then slide out the QWERTY keyboard and press **2. Tools, 4. Alarm Clock**.
2. Press the Directional Key  up or down to highlight an Alarm (1, 2, or 3), then press the Right Soft Key  [Options].
3. Select "Turn On/Turn Off" then press the OK Key  [OK].

RESET THE ALARM SETTING







1. From standby mode, press the OK Key  [OK] to unlock the keypad, then press the OK Key  [MENU], the Directional Key  right twice for **SETTINGS & TOOLS**, then slide out the QWERTY keyboard and press **2. Tools, 4. Alarm Clock**.
2. Press the Directional Key  up or down to highlight an Alarm (1, 2, or 3), then press the Right Soft Key  [Options].
3. Select "Reset Alarm", then press the Directional Key  up or down to select "Yes", then press the OK Key  [OK].

RESET ALL ALARM SETTINGS







1. From standby mode, press the OK Key  [OK] to unlock the keypad, then press the OK Key  [MENU], the Directional Key  right twice for **SETTINGS & TOOLS**, then slide out the QWERTY keyboard and press **2. Tools, 4. Alarm Clock**.
2. Press the Directional Key  up or down to highlight an Alarm (1, 2, or 3), then press the Right Soft Key  [Options].
3. Select "Reset All", then press the Directional Key  up or down to select "Yes", and then press the OK Key  [OK].







WORLD CLOCK

To display the time and date in pre-programmed cities:

1. From standby mode, press the OK Key  [OK] to unlock the keypad, then press the OK Key  [MENU], the Directional Key  right twice for **SETTINGS & TOOLS**, then slide out the QWERTY keyboard and press **2. Tools, 5. World Clock**.
2. Press the Left Soft Key  [Cities] to access the **CITIES LIST**. Press the Directional Key  up or down to select the city, then press the OK Key  [OK]. Or, press the Directional Key  up, down, left, or right to select your city using the world map.
3. The world map appears with the city, its date, and time.



DST (DAYLIGHT SAVING TIME) SETTING

1. Press the OK Key  [OK] to unlock the keypad, then press the Right Soft Key  [DST] to set the DST options. Press the Directional Key  left or right to select City and then press the Directional Key  down.
2. Press the Directional Key  left or right to turn DST (Daylight Savings Time) "On/Off". Press the Directional Key  down.

- Under “Start Date”, use the keypad to change or enter the start date and then press the Directional Key  down.
- Under “Start Time”, use the keypad to set a start time and press the Left Soft Key  for “am/pm” and then press the Directional Key  down.
- Under “End Date”, use the keypad to change or enter the end date and then press the Directional Key  down.
- Under “End Time”, use the keypad to set a end time and press the Left Soft Key  for “am/pm”.
- To save a DST setting, press the OK Key  [SAVE].

NOTEPAD





Your phone includes an internal notepad that can be used to compose and store reminders and notes. To create a note:

- From standby mode, press the OK Key  [OK] to unlock the keypad, then press the OK Key  [MENU], the Directional Key  right twice for **SETTINGS & TOOLS**, then slide out the QWERTY keyboard and press **2. Tools, 6. Notepad**.

- Press the Left Soft Key  [New] to write a new note. When you are done, press the OK Key  [SAVE].





VIEW SAVED MEMO

To view a saved memo:

- From standby mode, press the OK Key  [OK] to unlock the keypad, then press the OK Key  [MENU], the Directional Key  right twice for **SETTINGS & TOOLS**, then slide out the QWERTY keyboard and press **2. Tools, 6. Notepad**.
- Press the OK Key  [VIEW] to view a selected Note.





ERASE SAVED MEMO

To erase a saved memo:

- From standby mode, press the OK Key  [OK] to unlock the keypad, then press the OK Key  [MENU], the Directional Key  right twice for **SETTINGS & TOOLS**, then slide out the QWERTY keyboard and press **2. Tools, 6. Notepad**.
- Press the Right Soft Key  [Options], then select “Erase.”
- Press the OK Key  [OK] to select “Yes.”

ERASE ALL SAVED MEMOS

To erase all saved memos:



- From standby mode, press the OK Key  [OK] to unlock the keypad, then press the OK Key  [MENU], the Directional Key  right twice for **SETTINGS & TOOLS**, then slide out the QWERTY keyboard and press **2. Tools, 6. Notepad**.
- Press the Right Soft Key  [Options], then select “Erase All.”
- Press the OK Key  [OK] to select “Yes.”



STOP WATCH

Simultaneously times up to eight different events. To operate the stop watch:







- From standby mode, press the OK Key  [OK] to unlock the keypad, then press the OK Key  [MENU], the Directional Key  right twice for **SETTINGS & TOOLS**, then slide out the QWERTY keyboard and press **2. Tools, 7. Stop Watch**.

TO MEASURE A TIME PERIOD

- To start the stop watch, press the OK Key  [START].
- To pause it, press the OK Key  [STOP].



- To resume it, press the OK Key  [START].
- To reset it, press the Right Soft Key  [Reset].

TO TIME UP TO EIGHT EVENTS AT ONCE:

- To start the stop watch, press the OK Key  [START].
- To stop a time period and continue measuring another one, press the Left Soft Key  [Lap].
- To stop the second and continue measuring a third one, press the Left Soft Key  [Lap].
- To measure up to eight time periods, repeat the above steps.
- To stop the stop watch, press the OK Key  [STOP].
- To review the results, press the Left Soft Key  [View].
- To return to the stop watch, press the OK Key  [OK].
- To reset it, press the Right Soft Key  [Reset].

MY VERIZON

To access your Verizon account information:

1. From standby mode, press the OK Key  [OK] to unlock the keypad, then press the OK Key  [MENU], the Directional Key  right twice for **SETTINGS & TOOLS**, then slide out the QWERTY keyboard, and press **1. My Verizon**.

 **Shortcut:** In idle mode, press the Directional Key  left to access My Verizon.

MEDIA CENTER

Your phone provides a unique feature -Media Center- that enables you to download ringtones, wallpapers, games and more from your network to your phone. Please contact your service provider for the availability of these services.

Using the microSD card
Music & Tones
Pictures
Games
Mobile Web
Browse & Download
Extras
Media center info

USING THE microSD CARD

The microSD card stores sounds, images, photos and videos, music, and other files.

 The microSD card is sold separately, it does not come in-box.

INSTALLING THE microSD CARD

To install your microSD card:

1. With the microSD card slot opened and the gold contacts facing down, insert the microSD card into the slot.
2. Push the card in until it clicks into place. "MEMORY CARD DETECTED" will appear on the display. Close the microSD card slot.

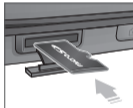

 To prevent possible damages, please keep microSD card slot closed at all times regardless of whether the microSD card is inserted or not.

REMOVING THE microSD CARD

To remove the microSD card:

1. Open the microSD card slot. Use your thumb to press and release the microSD card.



It will pop-out to allow you to remove the card.

2. Remove the card and close the microSD card slot.

- When you insert the microSD card, make sure contact terminals face down.
- Do not remove the microSD card while reading or writing files. Otherwise it could be damaged.

 To ensure the proper function of removable memory, please use a microSD card.

HOW IS MUSIC TRANSFERRED?

	Transfer from PC to Handset via USB Cable	Transfer from PC to Handset via Memory card
MP3 Songs	Yes	Yes
WMA Songs (Music ripped from CDs, e.g. unprotected content)	Yes	Yes
WMA Songs (Purchased from a Windows Media Player 10 music store such as V CAST Music, e.g. protected content)	Yes	Song will not play on the phone





-  Music acquired from another online store as part of a subscription service or purchased in another format other than WMA/MP3 will not be recognized by V CAST Music devices.
- V CAST Over The Air Music downloads are not available. Music can be purchased and downloaded via V CAST Music with Rhapsody through your PC. V CAST Music with Rhapsody will work with Windows Vista, XP, or 2000 (Only 32-bit versions of Windows are supported.) Not available for Mac or Linux.
- Only MP3 files with 192kbps or higher bitrate will be converted into WMA files.

MUSIC & TONES

To access the Music & Tones menu.

GET NEW RINGTONES





To connect to MEDIA CENTER and download various ringtones:

1. From standby mode, press the OK Key  [OK] to unlock the keypad. Press the OK Key  [MENU], the Directional Key  left twice for MEDIA CENTER, then slide out the QWERTY keyboard and press 1. Music & Tones, 1. Get New Ringtones.
2. If you have not downloaded any ringtones or ringtone applications previously, press "1. Get New Applications". The Media Center browser will launch. From the Download menu, select a service provider and press the OK Key . Then select the application and press the OK Key  to download it.







3. To download a ringtone, select the application from the Get New Ringtones menu. Once the application has launched, follow the directions to download your ringtones. Downloaded ringtones are saved to the "2. My Ringtones" menu.

MY RINGTONES

TO PLAY DOWNLOADED TUNES OR TONES:









1. From standby mode, press the OK Key  [OK] to unlock the keypad. Press the OK Key  [MENU], the Directional Key  left twice for MEDIA CENTER, then slide out the QWERTY keyboard and press 1. Music & Tones, 2. My Ringtones.
2. Select the tune or tone you want to play then press the OK Key  [PLAY].
3. To stop, press the OK Key  [STOP].

TO ERASE DOWNLOADED TUNES OR TONES:

- From standby mode, press the OK Key  [OK] to unlock the keypad. Press the OK Key  [MENU], the Directional Key  left twice for **MEDIA CENTER**, then slide out the QWERTY keyboard and press **1. Music & Tones, 2. My Ringtones**.
- Select the tune or tone you want to erase then press the Right Soft Key  [Options].
- Select **"1. Erase,"** then select **"Yes"** by pressing the OK Key  [OK].
 - If a **"Downloaded Ringtone"** is selected, press the Right Soft Key  [Options] to choose from the following:
 - Erase:** Erase the current ringtone from your phone.
 - Rename:** To edit the ringtone's title.
 - Lock:** Lock/Unlock the current ringtone from your phone.
 - Erase All:** To erase all the ringtones in your phone.
 - File Info:** Displays information on the selected ringtone.
 - If a **"Preloaded Sound"** is selected, pressing Right Soft Key  [Options], you can choose from the following:
 - Erase:** Erase the current ringtone from your phone.
 - Erase All:** To erase all the ringtones in your phone.
 - File Info:** Displays information on the selected ringtone.

TO ASSIGN DOWNLOADED TUNES OR TONES:







To select a desired ringtone, or download a new ringtone:





- From standby mode, press the OK Key  [OK] to unlock the keypad. Press the OK Key  [MENU], the Directional Key  left twice for **MEDIA CENTER**, then slide out the QWERTY keyboard and press **1. Music & Tones, 2. My Ringtones**.
- Press the Directional Key  up or down to highlight ringtone, then press the Left Soft Key  [Set As].
 - 1. Ringtone:** A confirmation message appears.
 - 2. Contact ID:** The Set As Contact ID screen appears. Select the Contact you want to assign the ringtone to, then press the OK Key  [OK].
 - 3. Alert Sounds:** Press the corresponding number key to set the ringtone for one of the following: **"All Messages"/"TXT Message"/"Pic-Voice Message"/"Voicemail"**. Press the Directional Key  up or down to highlight ringtone, then press the OK Key  [OK].
- Press the Right Soft Key  [Options] to access the following options:
 - Erase:** Erase the current ringtone from your phone.
 - Rename:** To edit the ringtone's title. (This option only appears for a downloaded ringtone)
 - Lock/Unlock:** Lock or unlock the current ringtone in your phone. (This option only appears for a downloaded ringtone)
 - Erase All:** To erase all the ringtones in your phone.

- File Info:** Displays information on the selected ringtone.

MY MUSIC







To playback and manage music stored in your phone's memory and on a memory card:

- From standby mode, press the OK Key  [OK] to unlock the keypad, then press the OK Key  [MENU], the Directional Key  left twice for **MEDIA CENTER**, then slide out the QWERTY keyboard and press **1. Music & Tones, 3. My Music**.
- The Music Library screen appears in the display with the following options:
 - 1. Genres / 2. Artists / 3. Albums / 4. Songs / 5. Playlists / 6. Play All / 7. Shuffle**
- To play a song, select **"4. Songs"**, scroll through the list of downloaded songs then press the OK Key  [Play]. To view your Playlists, select **"5. Playlists"**. Select **"6. Play All"** to play all your music, or select **"7. Shuffle"** to play your songs in random order.
- Press the Left Soft Key  [Repeat] to replay the song. Press the Right Soft Key  [Options] to **"1. Play All," "2. Shuffle," "3. My Music," "4. Help"**.

- Press the Directional Key  left to start the song over again. Press the Directional Key  right to skip to the next song if there are other songs to be played. Press the OK Key  [OK] to pause or play the song. If you press and hold the Directional Key  left the song rewinds and if you hold the Directional Key  right the song fast forwards.

MY SOUNDS

To select a desired sound or record a new sound:

- From standby mode, press the OK Key  [OK] to unlock the keypad, then press the OK Key  [MENU], the Directional Key  left twice for **MEDIA CENTER**, then slide out the QWERTY keyboard and press **1. Music & Tones, 4. My Sounds**.
- Press the Directional Key  up or down to highlight the sound, then press the OK Key  [PLAY] to hear the sound. Press the OK Key  [STOP] to stop playing the sound.
- Press the Right Soft Key  [Options] to access the following options:

- **DOWNLOADED or RECORDED SOUND:**

Send: To send a sound.

To Online Album: To upload selected sound to picture server.

Rename: To edit the sound's title.

Move: To move the selected sound to the other save location.

This option only appears if a memory card is inserted.

Lock/Unlock: Lock or unlock the selected sound in your phone.

Erase All: To erase all the sounds in your phone.

File Info: Displays information on the selected sound.

- **PRELOADED SOUND:**



Send: To send a sound.







To Online Album: To upload selected sound to picture server.

File Info: Displays information on the selected sound.





RECORDING NEW SOUNDS

To record a new sound:

1. From standby mode, press the OK Key  [OK] to unlock the keypad, then press the OK Key  [MENU], the Directional Key  left twice for **MEDIA CENTER**, then slide out the QWERTY keyboard and press **1. Music & Tones, 4. My Sounds**.
2. Press **"1. Record New"**.

3. Press the OK Key  [OK] to begin recording. When done, press the OK Key  [STOP] to finish recording. The recording is automatically saved to your **"My Sounds"** list.
4. Your recording is saved with a number. To rename your recording, scroll to it with the Directional Key  in the My Sounds menu, then press the Right Soft Key  [Options].
5. Press **"3. Rename"**.
6. Press and hold the Clear Key  to erase the number.
7. Enter the new name for your recording, then press the OK Key  [OK].

TO ERASE A SOUND:

1. From standby mode, press the OK Key  [OK] to unlock the keypad, then press the OK Key  [MENU], the Directional Key  left twice for **MEDIA CENTER**, then slide out the QWERTY keyboard and press **1. Music & Tones, 4. My Sounds**.
2. Press the Directional Key  up or down to select the sound you want to erase, and then press the Left Soft Key  [Erase]. **"ERASE SOUND FROM MY SOUNDS AND SETTINGS?"** will appear on your display.

3. Press the OK Key  [OK] to select **"Yes."** A confirmation message appears.



Your phone comes with 5 preloaded sounds: Clapping, Crowd roar, Happy Birthday, Rainforest, and Train. These cannot be erased.

SYNC MUSIC

SYNC YOUR MUSIC FROM YOUR PC TO YOUR V CAST MUSIC WITH RHAPSODY® CAPABLE PHONE

This option allows you to transfer music files from your PC. In order to use this option, you must install V CAST Music with Rhapsody on your PC.

1. Open V CAST Music with Rhapsody software. Don't have V CAST MUSIC with Rhapsody software? Download it for free at www.verizonwireless.com/music.
2. Plug in the USB cable (purchased separately) to your phone and connect it to a USB port on your PC.
3. From the main screen on your phone, the SYNC MUSIC V CAST MOBILE PHONE display appears. Your phone should display the message: Connected.

4. Drag and drop the song(s) you want to sync from My Library, to your V CAST Music with Rhapsody mobile phone, listed under the Sources tab. Once synchronization is complete, press the END/Power key ("Picture") and disconnect the USB cable (purchased separately).
5. Under the **"Music & Tones"** menu, open **"My Music"** to view and play your music.









- A compatible USB cable (included in-box) is required for syncing.
- V CAST Over The Air Music downloads are not available. Music can be purchased and downloaded via V CAST Music with Rhapsody through your PC. V CAST Music with Rhapsody will work with Windows Vista, XP, or 2000 (Only 32-bit versions of Windows are supported.) Not available for Mac or Linux.

PICTURES

GET NEW PICTURES





To connect to MEDIA CENTER and download a variety of Pictures (images):

1. From standby mode, press the OK Key  [OK] to unlock the keypad, then press the OK Key  [MENU], the Directional Key  left twice for **MEDIA CENTER**, then slide out the QWERTY keyboard and press **2. Pictures, 1. Get New Pictures**.
2. Press **"1. Get New Applications"**. Media Center will launch and take you to the download menu.
3. Press the Directional Key  up or down to select a provider's browser, and then press the OK Key  [OK].
4. Press the Directional Key  up or down, or press the OK Key  to select Application.
5. After executing the downloaded application, download the desired picture. The downloaded contents are saved in **"My Pictures"**.

 The downloaded application will be included in the list displayed when you access: **Get New Pictures > 1. Get New Applications**.







MY PICTURES

In My Pictures you can view all the pictures you have taken, store selected images in your phone, send pictures to the Online Album, delete images and access additional picture options.



1. From standby mode, press the OK Key  [OK] to unlock the keypad, then press the OK Key  [MENU], the Directional Key  left twice for **MEDIA CENTER**, then slide out the QWERTY keyboard and press **2. Pictures, 2. My Pictures**.
2. Press the Directional Key  up, down, left or right to select your desired pictures, then press the Right Soft Key  [Options].
3. Select one of the following options:
 - **Send:** To send a picture message.
 - **Set As:** Assigns the selected picture to display for specific tasks. (Wallpaper/Picture ID)
 - **To Online Album:** Access the Online Album.
 - **Take Picture:** Take a new picture.
 - **Get New Pictures:** Download various pictures.
 - **Rename:** Rename the selected picture.
 - **Move:** To move the picture to another save location. This only appears when a memory card is inserted.
 - **Lock/Unlock:** Lock or unlock the selected picture. Locked pictures cannot be deleted by the Erase All function. This option only appears for pictures you downloaded or took with the camera.
 - **Erase All:** To erase all the pictures in your phone. (From Card/From Phone)

- **File Info:** Displays information about the selected picture. (File Name/Date/Time/Resolution/Size)



TO ERASE THE CURRENT PICTURE:

1. From standby mode, press the OK Key  [OK] to unlock the keypad, then press the OK Key  [MENU], the Directional Key  left twice for **MEDIA CENTER**, then slide out the QWERTY keyboard and press **2. Pictures, 2. My Pictures**.
2. Press the Directional Key  up, down, left or right to select the picture you want to erase, and then press the Left Soft Key  [Erase]. **"ERASE PICTURE FROM MY PICTURES AND SETTINGS?"** will appear on your display.
3. Press the OK Key  [OK] to select **"Yes"**. A confirmation message appears.

TAKE PICTURE



1. To access the camera, press the Side Camera Key  when slide is opened.
 If the slide is closed, unlock the keypad by pressing the OK Key  [OK]. Press the Side Camera Key  to access the camera view mode.

2. Point the camera lens at your subject. You can check the picture framing through the display screen.

- Press the Directional Key  left/right: Zoom Down/Up. (Except 1280X960, 960X1280 mode).
- Pressing the Right Soft Key  [Options], you can choose from the following:
 1. **Resolution:** To select a resolution for a picture.
(Landscape: 1280x960/640x480/320x240/160x120,
Portrait: 960x1280/480x640/240x320/120x160)
 2. **Self Timer:** To activate the camera's timer function.
(Off/3 Seconds/5 Seconds/10 Seconds)
 3. **Brightness:** To brightness up/down(-2, -1, 0, +1, +2).
 4. **White Balance:** To select white balance.
(Auto/Sunny/Cloudy/Tungsten/Fluorescent/Darkness)
 5. **Shutter Sound:** To select a shutter sound. (Shutter/Silent/Say "Cheez"/Ready! 123)
 6. **Color Effects:** To select color effect among the following:
(Normal/Antique/Black and White/Negative)
 7. **Capture Mode:** To select Capture mode "Landscape" or "Portrait".



 To view captured images, press the Left Soft Key  [My Pics].

3. Press the Side Camera Key  Key or press the OK Key  [TAKE] to take the picture.

- After taking the picture it will be displayed.
To save the picture, press the Left Soft Key  [Save].
To take another picture without saving the picture you just took, press the Right Soft Key  [Erase].
To send the picture to someone, press the OK Key  [SEND].

ONLINE ALBUM





To access Online Album:

- From standby mode, press the OK Key  [OK] to unlock the keypad, then press the OK Key  [MENU], the Directional Key  left twice for **MEDIA CENTER**, then slide out the QWERTY keyboard and press **2. Pictures, 4. Online Album**. The browser launches, and the Online Album sign-on screen appears.
- Follow the on-screen prompts.

GAMES

DOWNLOADING NEW GAMES

To download games and applications from the MEDIA CENTER server:

- From standby mode, press the OK Key  [OK] to unlock the keypad, then press the OK Key  [MENU], the Directional Key  left twice for **MEDIA CENTER**, then slide out the QWERTY keyboard, and press **3. Games**.
- Press the OK Key  [OK] to “1. Get New Applications”.
- Choose the software you want from the list displayed on the screen.
- All applicable charges or fees will be incurred to download the selected application.
- Once download application, select “Yes” to run or “No” to return to the Games menu.

 In case of slide closed, first unlock the keypad by pressing the any key then press the OK Key  [OK].

PLAYING DOWNLOADED GAMES



- To play the game you downloaded, select the game then press the OK Key  [PLAY] to run the application.

MOBILE WEB

Now you can access news, sports, weather, and Email from your phone. Mobile Web 2.0 keeps you updated by providing access to up-to-date information such as news, sports, weather and stock quotes when you subscribe to Internet service with your service provider. Please contact your service provider for a list of available websites and service details.

- To start your Internet browser and access websites through your wireless handset press the Directional Key  up.

BROWSER MENU

The browser menu lists the actions necessary to operate the browser. To access, press the Directional Key  up and then press the Right Soft Key  [Menu].

VZW HOME

Returns the user to the home page.

ADD FAVORITE

Takes user to the VZW Add Favorite page.

 For favorites, page name and URL need to auto-populate.

SEARCH

Takes user to the VZW Search page.

GO TO URL

Takes user to the VZW Search > Go to Site page.

SHOW URL

Displays the current URL.

BACK

Returns to the previously viewed page.

MANAGE MEMORY

Displays the following list of options:

- **Clear Cache:** Clears the cache.
- **Clear History:** Clears the list of recently visited URLs.
- **Clear Cookies:** Clears saved cookies.
- **Autofill:** Automatically fills in character for browser recognized words.

SETTINGS

- **Downloads:** Selecting the “Downloads” item allows the user to enable/disable downloading images, background sounds, and object downloads when a URL is accessed.
- **Restart Browser:** Selecting “Restart Browser” causes the history and cache to be cleared and returns the user to the homepage.
- **Scroll Mode:** Selecting “Scroll Mode” from the Settings menu allows the user to select the way text scrolls and the scroll speed.
- **Send Referrer:** When the “Send Referrer” item is selected from the Settings menu, the browser allows the user to turn on or off sending the referrer URL.

- **Key Press Time Out:** When the “Key Press Timeout” item is selected from the Settings menu, the browser allows the user to set the key press timeout as fast, medium or slow. Medium is 1.5 seconds, slow 2 seconds and fast is 1 second. The key press timeout is the period of time after which the cursor auto-advances to the next entry position. In most cases, a single key can be used to enter more than one character. Each time the key is pressed the last character of the line is replaced by the next choice for that key. As long as the same key is repressed within key press timeout, the last character cycles between all the choices for the key.
- **Connection Time Out:** When the Connection Timeout item is selected from the Settings menu, the browser allows the user to set the connection timeout. The connection timeout determines how long the browser will wait for a response from the network for a network request.

ADVANCED

- **About:** Displays the name of the supplier of the Browser and the Browser SW version.
- **Refresh:** Allows the user to reload the current URL.
- **History:** Displays the previous 20 number of visited URLs, where X=20.
- **Encryption:** Displays the following list of options.
 1. **Authentication:** Gives the option to turn Authentication Caching ON or OFF.
 2. **Root Certificate:** Shows the root security keys for TLS.
 3. **Current Certificate:** Shows the current site security key for TLS (if applicable).







EXIT

Press the END Key  to exit out of the browser and return to idle mode.

BROWSE & DOWNLOAD

DOWNLOADING NEW APPLICATIONS





To download Tools that can help you navigate to entertainment spots, restaurants, and provide you with up-to-date weather information:

1. From standby mode, press the OK Key  [OK] to unlock the keypad, then press the OK Key  [MENU], the Directional Key  left twice for **MEDIA CENTER**, then slide out the QWERTY keyboard, and press **5. Browse & Download**.
2. Select “**Mobile Email**” or “**VZ Navigator**” with the Directional Key  then, press the OK Key  [OK].
 - **Mobile Email:** To connect to Brew Smartlink.
 - **VZ Navigator:** To connect to VZ Navigator.
3. Press the OK Key  [OK] for Get New Applications.

EXTRAS







DOWNLOADING NEW APPLICATIONS

To download Applications:

1. From standby mode, press the OK Key  [OK] to unlock the keypad, then press the OK Key  [MENU], the Directional Key  left twice for **MEDIA CENTER**, then slide out the QWERTY keyboard, and press **6. Extras**.
2. Press the OK Key  [OK] for “**1. Get New Applications**”.

MEDIA CENTER INFO

To view App. Memory, Phone Memory, View Log, and Help information:

1. From standby mode, press the OK Key  [OK] to unlock the keypad, then press the OK Key  [MENU].
2. Press the Directional Key  left twice for **MEDIA CENTER**.
3. Press the Right Soft Key  [Info].
4. Press the Directional Key  up or down to select one of the following settings, and then press the OK Key  [OK].
 - App. Memory / • Phone Memory / • View Log / • Help

CHAPTER 6

MESSAGING MENU

This chapter addresses Voicemail, TXT, Picture, Voice Messaging functions including:

When a new message arrives

New message

Inbox

Sent

Drafts

Voicemail

Mobile IM

Email

Chat

Erase all

Settings

WHEN A NEW MESSAGE ARRIVES

1. The following display appears when a new message arrives.
2. To display the message, select "View Now" and then press the OK Key [OK].



NEW MESSAGE

TXT MESSAGE

1. From standby mode, press the OK Key [OK] to unlock the keypad, then press the Left Soft Key [Message], then slide out the QWERTY keyboard, and press 1. **New Message**.
2. Press "1. **TXT Message**".
3. Under "To", input the phone number and then press the OK Key [OK].
 - By pressing the Right Soft Key [Add], you can choose from the following:
 1. **From Contacts**: Search for a phone number which is stored in the contacts list.
 2. **Recent Calls**: Search for a phone number which is stored in the recent calls list.
 3. **Groups**: Search the groups stored in the contacts list.
 4. **To Contacts**: Save the number or email you've entered to the contacts list, when you enter the number.

4. Under "Text", input a new TXT message. When completed, press the OK Key [SEND].

- By pressing the Right Soft Key [Options], you can choose from the following:
 1. **Save As Draft**: To save the TXT message.
 2. **Add**: To attach Quick Text, Graphic, Sound, Name Card.
 - **Quick Text**: Inserts already written sentences in TXT message.
 - **Graphic**: Inserts simple graphic images in TXT message.
 - **Sound**: Inserts EMS sound in TXT message.
 - **Name Card**: Inserts name card in TXT message.
 3. **Edit Text Format**: Allows you to edit the "Alignment", "Font Size", "Font Style", "Font Color", "Background Color".
 - **Alignment**: Select "Left", "Center" or "Right" by pressing the Directional Key [Left/Right].
 - **Font Size**: Select "Small", "Normal" or "Large" by pressing the Directional Key [Left/Right].
 - **Font Style**: Select "Strikethrough", "Normal", "Bold", "Italic" or "Underline" by pressing the Directional Key [Left/Right].
 - **Font Color**: Select Font color by pressing the Directional Key [Left/Right].
 - **Background Color**: Select Background color by pressing the Directional Key [Left/Right].
 4. **Priority Level**: Select "High" or "Normal" by pressing the Directional Key [Up/Down].
 5. **Cancel Message**: To cancel message.

If one of the fields is inserted in the TXT message field, the message is saved in the draft box.









PICTURE MESSAGE









1. From standby mode, press the OK Key [OK] to unlock the keypad, then press the Left Soft Key [Message], then slide out the QWERTY keyboard, and press 1. **New Message**.
2. Press "2. **Picture Message**".
3. Under "To", input the phone number and then press the OK Key [OK].
 - By pressing the Right Soft Key [Add], you can choose from the following:
 1. **From Contacts**: Search for a phone number which is stored in the contacts list.
 2. **Recent Calls**: Search for a phone number which is stored in the recent calls list.
 3. **Groups**: Search the groups stored in the contacts list.
 4. **To Online Album**: To send Picture message by using online Address.
 5. **To Contacts**: Save the number or email you've entered to the contacts list, when you enter the number.
4. Under "Text", input a New Picture Message and then press the Directional Key [Down].
5. Under "Picture", you can only insert/remove one picture. Press the Left Soft Key [My Pics] to select the picture you would like to send then press the OK Key [OK].
6. Under "Sound", you can only insert/remove one sound. Press the Left Soft Key [Sounds] to select the sound you would like to send

7. Under "Subject", input a subject and then press the Directional Key [Down].
8. Under "Name Card", you can insert your name card. Press the Left Soft Key [Add] select "1. **My Name Card**" or "2. **Contacts**" then press the OK Key [OK]. Select the card you'd like to send then press the OK Key [OK].
9. Press the Right Soft Key [Options] to access the following:
 - **Preview**: To preview a written Picture Message.
 - **Save As Draft**: To save the Picture Message.
 - **Add Quick Text**: Inserts already written sentences in Picture Message.
 - **Add Slide**: To add a another message.
 - **Priority Level**: Select "High" or "Normal" by pressing the Directional Key [Up/Down].
 - **Remove Picture**: To remove inserted picture in Picture field.
 - **Remove Slide**: To remove inserted Slide Message.
 - **Remove Sound**: To remove inserted sound in Sound field.
 - **Remove Name Card**: To remove inserted name card in Name Card field.
 - **Cancel Message**: To cancel message.
10. To send the Picture message, press the OK Key [SEND].

If one of the fields is inserted in Picture Message field, the message is saved in the draft box.

VOICE MESSAGE





- From standby mode, press the OK Key  [OK] to unlock the keypad, then press the Left Soft Key  [Message], then slide out the QWERTY keyboard, and press **1. New Message**.
- Press **3. Voice Message**.
- To record a new Voice Memo, press the OK Key  [OK] to start recording voice memo. Press the OK Key  [STOP] to stop recording voice memo and save it.
- Under **"To"**, input the phone number and then press the OK Key  [OK], then press the Directional Key  down.
 - By pressing the Right Soft Key  [Add], you can choose from the following:
 - From Contacts:** Search for a phone number which is stored in the contacts list.
 - Recent Calls:** Search for a phone number which is stored in the recent calls list.
 - Groups:** Search the groups stored in the contacts list.
 - To Online Album:** To send Voice message by using online Address.
 - To Contacts:** Save the number or email you've entered to the contacts list, when you enter the number.
- Under **"Voice"**, you can only Record/remove one Voice memo. Press the OK Key  [OK] to start recording voice memo. Press the OK Key  [STOP] to stop recording voice memo and save it.

- Under **"Text"**, input a New Voice Message and then press the Directional Key  down.
- Under **"Subject"**, input a subject and then press the Directional Key  down.
- Under **"Name Card"**, you can insert your name card. Press the Left Soft Key  [Add], select **"1. My Name Card"** or **"2. Contacts"** then press the OK Key  [OK]. Select the card you'd like to send then press the OK Key  [OK].
- Press the Right Soft Key  [Options] to access the following:
 - Review:** To preview a written Voice Message.
 - Save As Draft:** To save the Voice Message.
 - Add Quick Text:** Inserts already written sentences in Voice Message.
 - Priority Level:** Select "High" or "Normal" by pressing the Directional Key  up or down.
 - Remove Recording:** To remove inserted recorded voice memo in Voice field.
 - Remove Name Card:** To remove inserted name card in Name Card field.
 - Cancel Message:** To cancel message.
- To send the Voice message, press the OK Key  [SEND].











 If one of the fields is inserted in Voice Message field, the message is saved in the draft box.

INBOX

The Inbox manages received TXT, Picture, Voice, Web Alert messages. To access:

- From standby mode, press the OK Key  [OK] to unlock the keypad, then press the Left Soft Key  [Message], then slide out the QWERTY keyboard, and press **2. Inbox**.
- Select a message and then press the OK Key  [OPEN].
The message is displayed. To delete a message, press the Left Soft Key  [Erase], then press the OK Key  [OK] to select **"Yes"**.

MESSAGE ICON REFERENCE





 Read	 MMS Unread	 WAP Unread
 Unread	 MMS Read	 WAP Read
 Lock	 EMS Unread	
 Priority	 EMS Read	

- Press the Right Soft Key  [Options] to access the following:
 - Play Again:** To play a received Picture/Voice message.
 - Reply:** Type your reply.
 - Erase Inbox:** To erase all inbox message.
 - Reply W. Copy:** Select to reply with the original message included.
 - Forward:** Select to forward the TXT or Picture/Voice message.
 - Save Picture (MMS Picture):** Select to save a picture to the "My Pictures" folder.
 - Save As Ringtone (MMS Sound):** Select to save a sound to the "My Ringtones" folder.

- Save Sound (MMS Sound):** Select to save a sound to the "My Sounds" folder
- Save Objects (EMS Save Objects):** Select to save a graphic, sound, name card.
- Save Name Card:** Select to save a name card to the contacts.
- Save Quick Text:** Select to save received text msg to "Quick Text".
- Add To Contacts:** Select to save number to contacts.
- Extract Addresses:** To extract all Phone Numbers, Email Addresses and URLs from the received message.
- Lock/Unlock:** Select to lock or unlock the TXT, Picture or Voice message.
- Message Info:** Select to show received TXT/Picture/Voice message information.

SENT

Manages TXT, Picture, Voice messages already sent or waiting to be sent.

- From standby mode, press the OK Key  [OK] to unlock the keypad, then press the Left Soft Key  [Message], then slide out the QWERTY keyboard, and press **3. Sent**.
- Select a message and then press the OK Key  [OPEN].
The message is displayed. To delete a message, press the Left Soft Key  [Erase], then press the OK Key  [OK] to select **"Yes"**.

MESSAGE ICON REFERENCE

 Sent	 Delivered	 Sent Failed
 Lock	 Priority	 Incomplete Delivery

3. With the message open, press the Right Soft Key [Options] to access the following:

- **Play Again:** Select to play sent MMS message.
- **Forward:** Select to forward the TXT or Picture/Voice message.
- **Erase:** To erase a sent message.
- **Lock/Unlock:** Select to lock or unlock the TXT, Picture or Voice message.
- **Save Quick Text:** Select to save sent text msg to "Quick Text".
- **Add To Contacts:** Select to save number to contacts.
- **View Name Card:** To view include name card with in message.
- **Message Info:** Select to show received TXT/Picture/Voice message information.

DRAFTS

Draft Folder contains any draft messages or saved messages. If message composition is interrupted by a voice call or other interrupting event, the message of the current composition is automatically saved in the drafts folder.

1. From standby mode, press the OK Key [OK] to unlock the keypad, then press the Left Soft Key [Message], then slide out the QWERTY keyboard, and press 4. **Drafts**.
2. Select a message and then press the OK Key [EDIT]. The message is displayed.
3. To delete a message, press the Left Soft Key [Erase], then press the OK Key [OK] to select "Yes".

MESSAGE ICON REFERENCE



4. Press the Right Soft Key [Options] to access the following:

- **Send:** Select to send a selected message.
- **Lock/Unlock:** Select to lock or unlock the TXT, Picture or Voice message.
- **Add To Contacts:** Select to save number to contacts.
- **Erase Drafts:** To erase all drafts messages.

VOICEMAIL

New voicemail alerts are sent via an SMS text message. These messages indicate how many new and urgent voicemails are in your voicemail box. Open the text message to view the number of new voice messages in your voicemail. If a caller leaves a callback number, this number will also be sent via an SMS text message.

WHEN A NEW VOICEMAIL ARRIVES

When you receive a new voicemail message you'll hear a sound and a Voicemail appears in the display.

1. To display the message, select "Listen Now" or "Listen Later" by pressing the Directional Key up or down.
2. Press the OK Key [OK].

TO ACCESS YOUR VOICE MAILBOX

1. To dial voice mail directly, slide out the QWERTY keyboard and then press * Key, 8 Key, 6 Key and then the SEND Key. or From standby mode press the Left Soft Key [Message]. Press 5. **VoiceMail** then the SEND Key.
2. Follow the prompts to enter your lock code and retrieve your messages.

MOBILE IM

LAUNCHING MOBILE IM

1. From standby mode, press the OK Key [OK] to unlock the keypad, then press the Left Soft Key [Message], then slide out the QWERTY keyboard and press 6. **Mobile IM**, and then select "Mobile IM" for the Preloaded Mobile IM. 
2. The first time you access this feature an "Accept/Decline" screen will appear, select "Accept" by highlighting it and pressing the OK Key.







3. Choose from "AIM", "WL Messenger" and "Yahoo!". Highlight the messenger service and press the OK Key [OK]. 

4. Enter your Login ID and Password and then press the OK Key [Sing In] to Sign In.

DOWNLOAD NEW IM APPLICATIONS



1. From standby mode, press the OK Key [OK] to unlock the keypad, then press the Left Soft Key [Message], then slide out the QWERTY keyboard and press 1. **Get New Applications**. 

EMAIL

1. From standby mode, press the OK Key  [OK] to unlock the keypad, then press the Left Soft Key  [Message], then slide out the QWERTY keyboard and press 7. **Email**.
2. Select “**Mobile Email**” or “**Mobile Web Mail**” with the Directional Key  up or down, press the OK Key  [OK].
 - **Mobile Email:** To connect Brew Smartlink.
 - **Mobile Web Mail:** To connect WAP Browser.
3. Browser launches.
4. Press the Directional Key  up or down to select your Email provider, and then press the OK Key  [OK].
5. To send an Email, follow the on-screen prompts and functions.



CHAT

1. From standby mode, press the OK Key  [OK] to unlock the keypad, then press the Left Soft Key  [Message], then slide out the QWERTY keyboard and press 8. **Chat**.
2. Browser launches.

3. Press the Directional Key  up or down to select one of the displayed chat rooms, and then press the OK Key  [OK].
4. To chat with Internet Messenger users, follow the on-screen prompts and functions.

ERASE ALL

To erase all messages stored in your Inbox, Drafts or Sent folders:





1. From standby mode, press the OK Key  [OK] to unlock the keypad, then press the Left Soft Key  [Message], then the Right Soft Key  [Options].
 - Press “1. Erase Inbox” to erase all messages or only read message stored in the Inbox.
 - Press “2. Erase Drafts” to erase all messages stored in the Drafts folder.
 - Press “3. Erase Sent” to erase all messages stored in Sent Folder.
 - Press “4. Erase All” to erase all messages stored in the Inbox, Sent, and Drafts folders.

 Locked messages cannot be erased.

2. Select “**Yes**” to erase the selected messages, then press the OK Key  [OK]. A confirmation message appears.

SETTINGS

To configure received message settings:

1. From standby mode, press the OK Key  [OK] to unlock the keypad, then press the Left Soft Key  [Message], then the Left Soft Key  again for [Settings].
2. Press the Directional Key  up or down to highlight one of the settings below, then press the OK Key  [OK] to select it:

ENTRY MODE

Sets an Entry Mode as a default. For example, if Abc Mode is the default, its icon will appear.

1. Select “**Abc**,” “**ABC**” or “**123**” by pressing the Directional Key  up or down then press the OK Key  [OK].

AUTO SAVE



1. Select “**On**,” “**Off**” or “**Prompt**” by pressing the Directional Key  up or down then press the OK Key  [OK].
 - **On:** All sent messages saved in the Sent box.
 - **Off:** All sent messages not saved in the Sent box.
 - **Prompt:** “Yes,” “No” dialogue box displayed after sent message.

AUTO ERASE

Automatically erases inbox messages when new messages arrive.

1. Select “**On**” or “**Off**” by pressing the Directional Key  up or down then press the OK Key  [OK].
 - **On:** Oldest message erased from inbox automatically when Inbox is full.
 - **Off:** Oldest message not erased from inbox automatically when Inbox is full.

TXT AUTO VIEW





1. Select “**On**” or “**Off**” by pressing the Directional Key  up or down then press the OK Key  [OK].
 - **On:** TXT message displayed automatically.
 - **Off:** TXT message displayed by going to the inbox or responding to interactive notification.

PIC-VOICE AUTO RECEIVE

1. Select “**On**” or “**Off**” by pressing the Directional Key  up or down then press the OK Key  [OK].
 - **On:** Picture/Voice message downloaded automatically.
 - **Off:** Picture/Voice message must be retrieved from the inbox or at new Picture/Voice Message prompt.

QUICK TEXT

To edit the Quick Text you have saved:



1. Select a message from the list then press the OK Key  [EDIT].
2. To add a new Quick Text, press the Right Soft key  [New]. Enter the new text then press the OK Key  [SAVE].
3. To erase a saved Quick Text, press the Left Soft Key  [Erase]. Press the OK Key  [OK] to select "Yes".

VOICEMAIL#

1. Slide out the QWERTY keyboard and then input a new voicemail number or edit voicemail number then press the OK Key  [OK].

CALLBACK

Edits a default callback number so that the recipient can callback or reply.

1. Select "On" or "Off" by pressing the Directional Key  up or down then press the OK Key  [OK].
2. If "On" is selected, input a new callback number then press the OK Key  [OK].

SIGNATURE

Create a signature that can be automatically inserted at the end of all TXT, Picture and Voice messages.

1. To deactivate Signature function, select "None".
2. To input a "Signature", select "Custom". Enter your signature in the text box then press the OK Key  [OK].

SAFETY AND WARRANTY

This chapter addresses the safety guidelines and precautions to follow when operating your phone. Before operating your phone, please be aware of all the safety details. This chapter contains the terms and conditions of services and the warranty for your phone. Please review them thoroughly.

Safety information for wireless handheld phones
 Safety information for FCC RF exposure
 SAR information

FCC hearing-aid compatibility (HAC) regulations for wireless devices
 FDA consumer update
 Avoid potential hearing loss.
 FCC compliance information
 12 month limited warranty
 Index list

SAFETY INFORMATION FOR WIRELESS HANDHELD PHONES

READ THIS INFORMATION BEFORE USING YOUR HANDHELD PORTABLE CELLULAR TELEPHONE

EXPOSURE TO RADIO FREQUENCY SIGNALS

Your wireless handheld portable telephone is a low power radio transmitter and receiver. When it is ON, it receives and also sends out radio frequency (RF) signals.

In August 1996, the Federal Communications Commissions (FCC) adopted RF exposure guidelines with safety levels for handheld wireless phones. Those guidelines are consistent with the safety standards previously set by both U.S. and international standards bodies:

- ANSI C95.1 (1992) *
- NCRP Report 86 (1986) *
- ICNIRP (1996) *

Those standards were based on comprehensive and periodic evaluations of the relevant scientific literature. For example, over 120 scientists, engineers, and physicians from universities, government health agencies, and industry reviewed the available body of research to develop the ANSI Standard (C951).

The design of your phone complies with the FCC guidelines (and those standards).

1* : American National Standards Institute.

2* : National Council on Radiation protection and measurements.

3* : International Commission on Nonionizing Radiation Protection.

ANTENNA SAFETY

Use only the supplied or an approved replacement antenna. Unauthorized antennas, modifications, or attachments could impair call quality, damage the phone, or result in violation of FCC regulations. Please contact your local dealer for replacement antenna.

Do not use the phone with a damaged antenna. If a damaged antenna comes into contact with the skin, a minor burn may result. Please contact your local dealer for replacement antenna.

DRIVING SAFETY

Talking on the phone while driving is extremely dangerous and is illegal in some states. Remember, safety comes first. Check the laws and regulations on the use of phones in the areas where you drive. Always obey them. Also, if using your phone while driving, please:

- Give full attention to driving. Driving safely is your first responsibility.
- Use hands-free operation, if available.
- Pull off the road and park before making or answering a call, if driving conditions so require.

If you must use the phone while driving, please use one-touch, speed dialing, and auto answer modes.

An airbag inflates with great force. DO NOT place objects, including both installed or portable wireless equipment, in the area over the airbag or in the air bag deployment area. If in-vehicle wireless equipment is improperly installed and the air bag inflates, serious injury could result.



WARNING: Failure to follow these instructions may lead to serious personal injury and possible property damage.

ELECTRONIC DEVICES

Your wireless handheld portable telephone is a low power radio transmitter and receiver. When it is ON, it receives and also sends out radio frequency (RF) signals.

Most modern electronic equipment is shielded from RF energy. However, certain electronic equipment may not be shielded against the RF signals from your wireless phone. Therefore, use of your phone must be restricted in certain situations.

PACEMAKERS

The Health Industry Manufacturers Association recommends that a minimum separation of six (6") inches be maintained between a handheld wireless phone and a pacemaker to avoid potential interference with the pacemaker. These recommendations are consistent with the independent research by and recommendations of Wireless Technology Research. Persons with pacemakers:

- ALWAYS keep the phone more than six inches from your pacemaker when the phone is turned on.
- Do not carry the phone in a breast pocket.
- Use the ear opposite the pacemaker to minimize the potential for interference.
- If you have any reason to suspect that interference is taking place, turn your phone OFF immediately.

HEARING AIDS

Some digital wireless phones may interfere with some hearing aids. In the event of such interference, you may want to consult your service provider (or call the customer service line to discuss alternatives).

OTHER MEDICAL DEVICES

If you use any other personal medical device, consult the manufacturer of your device to determine if they are adequately shielded from external RF energy. Your physician may be able to assist you in obtaining this information.

Turn your phone OFF in healthcare facilities when any regulations posted in these areas instruct you to do so. Hospitals or healthcare facilities may be using equipment that could be sensitive to external RF energy.

VEHICLES

RF signals may affect improperly installed or inadequately shielded electronic systems in motor vehicles. Check with the manufacturer or its representative regarding

your vehicle. You should also consult the manufacturer of any equipment that has been added to your vehicle.

POSTED FACILITIES

Turn your phone OFF where posted notices so require.

OTHER SAFETY GUIDELINES

AIRCRAFT

FCC regulations prohibit using your phone while in the air. Turn your phone OFF before boarding an aircraft. Always request and obtain prior consent and approval of an authorized airline representative before using your phone aboard an aircraft. Always follow the instructions of the airline representative whenever using your phone aboard an aircraft, to prevent any possible interference with airborne electronic equipment.

BLASTING AREAS

To avoid interfering with blasting operations, turn your phone OFF when in a "blasting area" or in areas posted: "Turn off two-way radio." Obey all signs and instructions.

POTENTIALLY EXPLOSIVE ATMOSPHERES

Turn your phone OFF when in any area with a potentially explosive atmosphere and

obey all signs and instructions. Sparks in such areas could cause an explosion or fire resulting in bodily injury or even death.

Areas with a potentially explosive atmosphere are often, but not always, clearly marked. They include fueling areas such as gas stations; below deck on boats; fuel or chemical transfer or storage facilities; vehicles using liquefied petroleum gas (such as propane or butane); areas where the air contains chemicals or particles, such as grain, dust, or metal powders; and any other area where you would normally be advised to turn off your vehicle's engine.

PRECAUTIONS

Your Handheld Portable Telephone is a high quality piece of equipment. Before operating, read all instructions and cautionary markings on (1) AC/DC Travel Adaptor (2) Battery and (3) Product Using Battery.

Failure to follow the directions below could result in serious bodily injury and/or property damage due to battery liquid leakage, fire or rupture.

- DO NOT use this equipment in an extreme environment where high temperature or high humidity exists.
- DO NOT abuse the equipment. Avoid striking, shaking or shocking. When not using, lay down the unit to avoid possible damage due to instability.
- DO NOT expose this equipment to rain or spilled beverages.
- DO NOT use unauthorized accessories.
- DO NOT disassemble the phone or its accessories. If service or repair is required,

return unit to an authorized UTStarcom cellular service center. If unit is disassembled, the risk of electric shock or fire may result.

- DO NOT short-circuit the battery terminals with metal items etc.

SAFETY INFORMATION FOR FCC RF EXPOSURE

WARNING! READ THIS INFORMATION BEFORE USING

CAUTIONS

In August 1996 the Federal Communications Commission (FCC) of the United States with its action in Report and Order FCC 96-326 adopted an updated safety standard for human exposure to radio frequency electromagnetic energy emitted by FCC regulated transmitters. Those guidelines are consistent with the safety standard previously set by both U.S. and international standards bodies. The design of this phone complies with the FCC guidelines and these international standards.

BODY-WORN OPERATION

This device was tested for typical body-worn operations with the back of the phone kept 1.5 cm. from the body. To maintain compliance requirements, use only belt-clips, holsters or similar accessories that maintain a 1.5 cm separation distance between the user's Body and the back of the phone, including the antenna. The use of belt-clips, holsters and similar accessories should not contain metallic components in its assembly. The use of accessories that do not satisfy these requirements may not comply with FCC RF exposure requirements, and should be

avoided.



For more information about RF exposure, please visit the FCC website at www.fcc.gov.

SAR INFORMATION

THIS MODEL PHONE MEETS THE GOVERNMENT'S REQUIREMENTS FOR EXPOSURE TO RADIO WAVES.

Your wireless phone is a radio transmitter and receiver. It is designed and manufactured not to exceed the emission limits for exposure to radiofrequency (RF) energy set by the Federal Communications Commission of the U.S. Government. These limits are part of comprehensive guidelines and establish permitted levels of RF energy for the general population. The guidelines are based on standards that were developed by independent scientific organizations through periodic and thorough evaluation of scientific studies. The standards include a substantial safety margin designed to assure the safety of all persons, regardless of age and health.

The exposure standard for wireless mobile phones employs a unit of measurement known as the Specific Absorption Rate, or SAR. The SAR limit set by the FCC is 1.6 W/kg. * Tests for SAR are conducted with the phone transmitting at its highest certified power level in all tested frequency bands. Although the SAR is determined at the highest certified power level, the actual SAR level of the phone while operating can be well below the maximum value. This is because the phone is designed to operate at multiple power levels so as to use only the power required to reach the

network. In general, the closer you are to a wireless base station antenna, the lower the power output.

Before a phone model is available for sale to the public, it must be tested and certified to the FCC that it does not exceed the limit established by the government adopted requirement for safe exposure. The tests are performed in positions and locations (e.g., at the ear and worn on the body) as required by the FCC for each model. The highest SAR value for this model phone when tested for use at the ear is 1.19 W/Kg and when worn on the body, as described in this user guide, is 0.694 W/Kg. (Body-worn measurements differ among phone models, depending upon available accessories and FCC requirements). While there may be differences between the SAR levels of various phones and at various positions, they all meet the government requirement for safe exposure.

The SAR testing for Body-worn operation was performed with a belt clip that provided a 22mm separation. The User's Manual indicates that any holsters/clips used with this device should contain no metallic components.

The FCC has granted an Equipment Authorization for this model phone with all reported SAR levels evaluated as in compliance with the FCC RF exposure guidelines. SAR information on this model phone is on file with the FCC and can be found under the Display Grant section of <http://www.fcc.gov/oet/ea> after searching on PP4ELVIS.

Additional information on Specific Absorption Rates (SAR) can be found on the Cellular Telecommunications Industry Association (CTIA) web-site at <http://www.wow-com.com>.

* In the United States and Canada, the SAR limit for mobile phones used by the public is 1.6 watts/kg (W/kg) averaged over one gram of tissue. The standard incorporates a sub-stancial margin of safety to give additional protection for the public and to account for any variations in measurements.

FCC HEARING-AID COMPATIBILITY (HAC) REGULATIONS FOR WIRELESS DEVICES

On July 10, 2003, the U.S. Federal Communications Commission (FCC) Report and Order in WT Docket 01-309 modified the exception of wireless phones under the Hearing Aid Compatibility Act of 1988 (HAC Act) to require digital wireless phones be compatible with hearing-aids. The intent of the HAC Act is to ensure reasonable access to telecommunications services for persons with hearing disabilities.

While some wireless phones are used near some hearing devices (hearing aids and cochlear implants), users may detect a buzzing, humming, or whining noise. Some hearing devices are more immune than others to this interference noise, and phones also vary in the amount of interference they generate.

The wireless telephone industry has developed a rating system for wireless phones, to assist hearing device users find phones that may be compatible with their hearing devices. Not all phones have been rated. Phones that are rated have the rating on their box or a label located on the box.

The ratings are not guarantees. Results will vary depending on the user's hearing device and hearing loss. If your hearing device happens to be vulnerable to interfer-

ence, you may not be able to use a rated phone successfully. Trying out the phone with your hearing device is the best way to evaluate it for your personal needs.

M-Ratings: Phones rated M3 or M4 meet FCC requirements and are likely to generate less interference to hearing devices than phones that are not labeled. M4 is the better/higher of the two ratings.



Hearing devices may also be rated. Your hearing device manufacturer or hearing health professional may help you find this rating. Higher ratings mean that the hearing device is relatively immune to interference noise.

The hearing aid and wireless phone rating values are then added together. A sum of 5 is considered acceptable for normal use. A sum of 6 is considered for best use.

In the above example, if a hearing aid meets the M2 level rating and the wireless phone meets the M3 level rating, the sum of the two values equal M5. This should provide the hearing aid user with "normal usage" while using their hearing aid with the particular wireless phone. "Normal usage" in this context is defined as a signal quality that is acceptable for normal operation.

The M mark is intended to be synonymous with the U mark. The T mark is intended to be synonymous with the UT mark. The M and T marks are recommended by the Alliance for Telecommunications Industries Solutions (ATIS). The U and UT marks are referenced in Section 20.19 of the FCC Rules. The HAC rating and measurement procedure are described in the American National Standards Institute (ANSI) C63.19 standard.

For information about hearing aids and digital wireless phone

- Fcc Hearing Aid Compatibility and Volume Control <http://www.fcc.gov/cgb/dro/hearing.html>
- Gallaudet University, RERC <http://tap.gallaudet.edu/DigWireless.KS/DigWireless.htm>
- Self Help for Hard of Hearing People Inc. [SHHH] www.hearingloss.org/hat/TipsWirelessPhones.htm
- The Hearing Aid Compatibility FCC Order http://hraunfoss.fcc.gov/edocs_public/attachmatch/FCC-03-168A1.pdf

FDA CONSUMER UPDATE



U.S. FOOD AND DRUG ADMINISTRATION - CENTER
FOR DEVICES AND RADIOLOGICAL HEALTH
CONSUMER UPDATE ON WIRELESS PHONES

1. Do wireless phones pose a health hazard?

The available scientific evidence does not show that any health problems are associated with using wireless phones. There is no proof, however, that wireless phones are absolutely safe. Wireless phones emit low levels of radiofrequency energy (RF) in the microwave range while being used. They also emit very low levels of RF when in the stand-by mode. Whereas high levels of RF can produce health effects (by heating tissue), exposure to low level RF that does not produce heating effects causes no known adverse health effects. Many studies of low level RF exposures have not found any biological effects. Some studies have suggested that some biological effects may occur, but such findings have not been confirmed by additional research. In some cases, other researchers have had difficulty in reproducing those studies, or in determining the reasons for inconsistent results.

2. What is FDA's role concerning the safety of wireless phones?

Under the law, FDA does not review the safety of radiation-emitting consumer products such as wireless phones before they can be sold, as it does with new drugs or medical devices. However, the agency has authority to take action if wireless phones are shown to emit radiofrequency energy (RF) at a level that is hazardous to

the user. In such a case, FDA could require the manufacturers of wireless phones to notify users of the health hazard and to repair, replace or recall the phones so that the hazard no longer exists. Although the existing scientific data do not justify FDA regulatory actions, FDA has urged the wireless phone industry to take a number of steps, including the following:

- Support needed research into possible biological effects of RF of the type emitted by wireless phones;
 - Design wireless phones in a way that minimizes any RF exposure to the user that is not necessary for device function;
- and
- Cooperate in providing users of wireless phones with the best possible information on possible effects of wireless phone use on human health.

FDA belongs to an interagency working group of the federal agencies that have responsibility for different aspects of RF safety to ensure coordinated efforts at the federal level. The following agencies belong to this working group:

- National Institute for Occupational Safety and Health
- Environmental Protection Agency
- Federal Communications Commission
- Occupational Safety and Health Administration
- National Telecommunications and Information Administration

The National Institutes of Health participates in some inter-agency working group activities, as well. FDA shares regulatory responsibilities for wireless phones with the

Federal Communications Commission (FCC). All phones that are sold in the United States must comply with FCC safety guidelines that limit RF exposure. FCC relies on FDA and other health agencies for safety questions about wireless phones. FCC also regulates the base stations that the wireless phone networks rely upon. While these base stations operate at higher power than do the wireless phones themselves, the RF exposures that people get from these base stations are typically thousands of times lower than those they can get from wireless phones. Base stations are thus not the subject of the safety questions discussed in this document.

3. What kinds of phones are the subject of this update?

The term "wireless phone" refers here to hand-held wireless phones with built-in antennas, often called "cell," "mobile," or "PCS" phones. These types of wireless phones can expose the user to measurable radiofrequency energy (RF) because of the short distance between the phone and the user's head. These RF exposures are limited by Federal Communications Commission safety guidelines that were developed with the advice of FDA and other federal health and safety agencies. When the phone is located at greater distances from the user, the exposure to RF is drastically lower because a person's RF exposure decreases rapidly with increasing distance from the source. The so-called "cordless phones," which have a base unit connected to the telephone wiring in a house, typically operate at far lower power levels, and thus produce RF exposures far below the FCC safety limits.

4. What are the results of the research done already?

The research done thus far has produced conflicting results, and many studies have

suffered from flaws in their research methods. Animal experiments investigating the effects of radiofrequency energy (RF) exposures characteristic of wireless phones have yielded conflicting results that often cannot be repeated in other laboratories. A few animal studies, however, have suggested that low levels of RF could accelerate the development of cancer in laboratory animals.

However, many of the studies that showed increased tumor development used animals that had been genetically engineered or treated with cancer-causing chemicals so as to be predisposed to develop cancer in the absence of RF exposure. Other studies exposed the animals to RF for up to 22 hours per day. These conditions are not similar to the conditions under which people use wireless phones, so we don't know with certainty what the results of such studies mean for human health. Three large epidemiology studies have been published since December 2000. Between them, the studies investigated any possible association between the use of wireless phones and primary brain cancer, glioma, meningioma, or acoustic neuroma, tumors of the brain or salivary gland, leukemia, or other cancers. None of the studies demonstrated the existence of any harmful health effects from wireless phone RF exposures. However, none of the studies can answer questions about long-term exposures, since the average period of phone use in these studies was around three years.

5. What research is needed to decide whether RF exposure from wireless phones poses a health risk?

A combination of laboratory studies and epidemiological studies of people actually

using wireless phones would provide some of the data that are needed. Lifetime animal exposure studies could be completed in a few years. However, very large numbers of animals would be needed to provide reliable proof of a cancer promoting effect if one exists. Epidemiological studies can provide data that is directly applicable to human populations, but 10 or more years' follow-up may be needed to provide answers about some health effects, such as cancer. This is because the interval between the time of exposure to a cancer-causing agent and the time tumors develop - if they do - may be many, many years. The interpretation of epidemiological studies is hampered by difficulties in measuring actual RF exposure during day-to-day use of wireless phones. Many factors affect this measurement, such as the angle at which the phone is held, or which model of phone is used.

6. What is FDA doing to find out more about the possible health effects of wireless phone RF?

FDA is working with the U.S. National Toxicology Program and with groups of investigators around the world to ensure that high priority animal studies are conducted to address important questions about the effects of exposure to radiofrequency energy (RF). FDA has been a leading participant in the World Health Organization International Electromagnetic Fields (EMF) Project since its inception in 1996. An influential result of this work has been the development of a detailed agenda of research needs that has driven the establishment of new research programs around the world. The Project has also helped develop a series of public information documents on EMF issues. FDA and the Cellular Telecommunications & Internet Association (CTIA) have a formal Cooperative Research and Development Agreement

(CRADA) to do research on wireless phone safety. FDA provides the scientific oversight, obtaining input from experts in government, industry, and academic organizations. CTIA-funded research is conducted through contracts to independent investigators. The initial research will include both laboratory studies and studies of wireless phone users. The CRADA will also include a broad assessment of additional research needs in the context of the latest research developments around the world.

7. How can I find out how much radiofrequency energy exposure I can get by using my wireless phone?

All phones sold in the United States must comply with Federal Communications Commission (FCC) guidelines that limit radiofrequency energy (RF) exposures. FCC established these guidelines in consultation with FDA and the other federal health and safety agencies. The FCC limit for RF exposure from wireless telephones is set at a Specific Absorption Rate (SAR) of 1.6 watts per kilogram (1.6 W/kg). The FCC limit is consistent with the safety standards developed by the Institute of Electrical and Electronic Engineering (IEEE) and the National Council on Radiation Protection and Measurement. The exposure limit takes into consideration the body's ability to remove heat from the tissues that absorb energy from the wireless phone and is set well below levels known to have effects. Manufacturers of wireless phones must report the RF exposure level for each model of phone to the FCC. The FCC website (<http://www.fcc.gov/oet/rfsafety>) gives directions for locating the FCC identification number on your phone so you can find your phone's RF exposure level in the online listing.

8. What has FDA done to measure the radiofrequency energy coming from wireless phones?

The Institute of Electrical and Electronic Engineers (IEEE) is developing a technical standard for measuring the radiofrequency energy (RF) exposure from wireless phones and other wireless handsets with the participation and leadership of FDA scientists and engineers. The standard, "Recommended Practice for Determining the Spatial-Peak Specific Absorption Rate (SAR) in the Human Body Due to Wireless Communications Devices: Experimental Techniques," sets forth the first consistent test methodology for measuring the rate at which RF is deposited in the heads of wireless phone users. The test method uses a tissue-simulating model of the human head. Standardized SAR test methodology is expected to greatly improve the consistency of measurements made at different laboratories on the same phone. SAR is the measurement of the amount of energy absorbed in tissue, either by the whole body or a small part of the body. It is measured in watts/kg (or milliwatts/g) of matter. This measurement is used to determine whether a wireless phone complies with safety guidelines.

9. What steps can I take to reduce my exposure to radiofrequency energy from my wireless phone?

If there is a risk from these products—and at this point we do not know that there is—it is probably very small. But if you are concerned about avoiding even potential risks, you can take a few simple steps to minimize your exposure to radiofrequency energy (RF). Since time is a key factor in how much exposure a person receives, reducing the amount of time spent using a wireless phone will reduce RF exposure.

- If you must conduct extended conversations by wireless phone every day, you could place more distance between your body and the source of the RF, since the exposure level drops off dramatically with distance.

For example, you could use a headset and carry the wireless phone away from your body or use a wireless phone connected to a remote antenna. Again, the scientific data do not demonstrate that wireless phones are harmful. But if you are concerned about the RF exposure from these products, you can use measures like those described above to reduce your RF exposure from wireless phone use.

10. What about children using wireless phones?

The scientific evidence does not show a danger to users of wireless phones, including children and teenagers. If you want to take steps to lower exposure to radiofrequency energy (RF), the measures described above would apply to children and teenagers using wireless phones. Reducing the time of wireless phone use and increasing the distance between the user and the RF source will reduce RF exposure. Some groups sponsored by other national governments have advised that children be discouraged from using wireless phones at all. For example, the government in the United Kingdom distributed leaflets containing such a recommendation in December 2000. They noted that no evidence exists that using a wireless phone causes brain tumors or other ill effects. Their recommendation to limit wireless phone use by children was strictly precautionary; it was not based on scientific evidence that any health hazard exists.

11. What about wireless phone interference with medical equipment?

Radiofrequency energy (RF) from wireless phones can interact with some electronic devices. For this reason, FDA helped develop a detailed test method to measure electromagnetic interference (EMI) of implanted cardiac pacemakers and defibrillators from wireless telephones. This test method is now part of a standard sponsored by the Association for the Advancement of Medical Instrumentation (AAMI). The final draft, a joint effort by FDA, medical device manufacturers, and many other groups, was completed in late 2000. This standard will allow manufacturers to ensure that cardiac pacemakers and defibrillators are safe from wireless phone EMI. FDA has tested hearing aids for interference from handheld wireless phones and helped develop a voluntary standard sponsored by the Institute of Electrical and Electronic Engineers (IEEE). This standard specifies test methods and performance requirements for hearing aids and wireless phones so that no interference occurs when a person uses a “compatible” phone and a “compatible” hearing aid at the same time. This standard was approved by the IEEE in 2000. FDA continues to monitor the use of wireless phones for possible interactions with other medical devices. Should harmful interference be found to occur, FDA will conduct testing to assess the interference and work to resolve the problem.

12. Where can I find additional information?

For additional information, please refer to the following resources:

- FDA web page on wireless phones (<http://www.fda.gov/cellphones>)

- Federal Communications Commission (FCC) RF Safety Program (<http://www.fcc.gov/oet/rfsafety>)
- International Commission on Non-Ionizing Radiation Protection (<http://www.icnirp.de>)
- World Health Organization (WHO) International EMF Project (<http://www.who.int/emf>)
- National Radiological Protection Board (UK) (<http://www.hpa.org.uk/radiation/>)

AVOID POTENTIAL HEARING LOSS.

Prolonged exposure to loud sounds (including music) is the most common cause of preventable hearing loss. Some scientific research suggests that using portable audio devices, such as portable music players and cellular telephones, at high volume settings for long durations may lead to permanent noise-induced hearing loss. This includes the use of headphones (including headsets, earbuds and Bluetooth® or other wireless devices). Exposure to very loud sound has also been associated in some studies with tinnitus (a ringing in the ear), hypersensitivity to sound and distorted hearing. Individual susceptibility to noise-induced hearing loss and other potential hearing problems varies.

The amount of sound produced by a portable audio device varies depending on the nature of the sound, the device, the device settings and the headphones. You should follow some commonsense recommendations when using any portable audio device:

- Set the volume in a quiet environment and select the lowest volume at which you can hear adequately.
- When using headphones, turn the volume down if you cannot hear the people speaking near you or if the person sitting next to you can hear what you are listening to.
- Do not turn the volume up to block out noisy surroundings. If you choose to listen to your portable device in a noisy environment, use noise-cancelling headphones to block out background environmental noise.
- Limit the amount of time you listen. As the volume increases, less time is required before your hearing could be affected.
- Avoid using headphones after exposure to extremely loud noises, such as rock concerts, that might cause temporary hearing loss. Temporary hearing loss might cause unsafe volumes to sound normal.
- Do not listen at any volume that causes you discomfort. If you experience ringing in your ears, hear muffled speech or experience any temporary hearing difficulty after listening to your portable audio device, discontinue use and consult your doctor.

YOU CAN OBTAIN ADDITIONAL INFORMATION ON THIS SUBJECT FROM THE FOLLOWING SOURCES:

American Academy of Audiology

11730 Plaza American Drive, Suite 300
Reston, VA 20190
Voice: 800-AAA-2336, 703-790-8466
Email: info@audiology.org
Internet: www.audiology.org

National Institute on Deafness and Other Communication Disorders National Institutes of Health

31 Center Drive, MSC 2320
Bethesda, MD USA 20892-2320
Voice: (301) 496-7243
Email: nidcdinfo@nidcd.nih.gov
Internet: <http://www.nidcd.nih.gov/health/hearing>

National Institute for Occupational Safety and Health

Hubert H. Humphrey Bldg.
200 Independence Ave., SW
Washington, DC 20201
Voice: 1-800-CDC-INFO (1-800-232-4636)
Internet: <http://www.cdc.gov/niosh/topics/noise/default.html>

FCC COMPLIANCE INFORMATION

This device complies with Part 15 of FCC Rules.

Operation is subject to the following two conditions:

- (1) This device may not cause harmful interference, and
- (2) This device must accept any interference received.
Including interference that may cause undesired operation.

INFORMATION TO THE USER

This equipment has been tested and found to comply with the limits for a Class B digital device pursuant to Part 15 of the FCC Rules. These limits are designed to provide reasonable protection against harmful Interference in a residential installation. This equipment generates, uses, and can radiate radio frequency energy and, if Not installed and used in accordance with the instructions, may cause harmful Interference to radio communications. However, there is no guarantee that interference will not occur in a particular Installation. If this equipment does cause harmful interference to radio or television reception, which can be determined by turning the equipment off and on, the user is encouraged to try to correct the interference by one or more of the following measures:

- Reorient or relocate the receiving antenna.
Increase the separation between the equipment and receiver.
- Connect the equipment into an outlet of a circuit different from that to which the receiver is connected.

- Consult the dealer or an experienced radio/TV technician for assistance.



CAUTION: Changes or modification not expressly approved by the party responsible for Compliance could void the user's authority to operate the equipment. Connecting of peripherals requires the use of grounded shielded signal cables.

©2008 Verizon Wireless. All Rights Reserved.

12 MONTH LIMITED WARRANTY

UTStarcom Personal Communications (the Company) warrants to the original retail purchaser of this UTStarcom handheld portable cellular telephone, that should this product or any part thereof during normal consumer usage and conditions, be proven defective in material or workmanship that results in product failure within the first twelve (12) month period from the date of purchase, such defect(s) will be repaired or replaced (with new or rebuilt parts) at the Company's option, without charge for parts or labor directly related to the defect(s).

The antenna, keypad, display, rechargeable battery and battery charger, if included, are similarly warranted for twelve (12) months from date of purchase.

This Warranty extends only to consumers who purchase the product in the United States or Canada and it is not transferable or assignable.

This Warranty does not apply to:

- (a) Product subjected to abnormal use or conditions, accident, mishandling, neglect, unauthorized alteration, misuse, improper installation or repair or improper storage;
- (b) Product whose mechanical serial number or electronic serial number has been removed, altered or defaced.
- (c) Damage from exposure to moisture, humidity, excessive temperatures or extreme environmental conditions;
- (d) Damage resulting from connection to, or use of any accessory or other product

not approved or authorized by the Company;

- (e) Defects in appearance, cosmetic, decorative or structural items such as framing and non-operative parts;
- (f) Product damaged from external causes such as fire, flooding, dirt, sand, weather conditions, battery leakage, blown fuse, theft or improper usage of any electrical source.

The Company disclaims liability for removal or reinstallation of the product, for geographic coverage, for inadequate signal reception by the antenna or for communications range or operation of the cellular system as a whole.

When sending your wireless device to UTStarcom Personal Communications for repair or service, please note that any personal data or software stored on the device may be inadvertently erased or altered. Therefore, we strongly recommend you make a back up copy of all data and software contained on your device before submitting it for repair or service. This includes all contact lists, downloads (i.e. third-party software applications, ringtones, games and graphics) and any other data added to your device. In addition, if your wireless device utilizes a SIM or Multimedia card, please remove the card before submitting the device and store for later use when your device is returned, UTStarcom Personal Communications is not responsible for and does not guarantee restoration of any third-party software, personal information or memory data contained in, stored on, or integrated with any wireless device, whether under warranty or not, returned to UTStarcom Personal Communications for repair or service.

To obtain repairs or replacement within the terms of this Warranty, the product should be delivered with proof of Warranty coverage (e.g. dated bill of sale), the consumer's return address, daytime phone number and/or fax number and complete description of the problem, transportation prepaid, to the Company at the address shown below or to the place of purchase for repair or replacement processing. In addition, for reference to an authorized Warranty station in your area, you may telephone in the United States (800) 229-1235, and in Canada (800) 465-9672 (in Ontario call 416-695-3060).

THE EXTENT OF THE COMPANY'S LIABILITY UNDER THIS WARRANTY IS LIMITED TO THE REPAIR OR REPLACEMENT PROVIDED ABOVE AND, IN NO EVENT, SHALL THE COMPANY'S LIABILITY EXCEED THE PURCHASE PRICE PAID BY PURCHASER FOR THE PRODUCT.

ANY IMPLIED WARRANTIES, INCLUDING ANY IMPLIED WARRANTY OF MERCHANTABILITY OR FITNESS FOR A PARTICULAR PURPOSE, SHALL BE LIMITED TO THE DURATION OF THIS WRITTEN WARRANTY. ANY ACTION FOR BREACH OF ANY WARRANTY MUST BE BROUGHT WITHIN A PERIOD OF 18 MONTHS FROM DATE OF ORIGINAL PURCHASE. IN NO CASE SHALL THE COMPANY BE LIABLE FOR AN SPECIAL CONSEQUENTIAL OR INCIDENTAL DAMAGES FOR BREACH OF THIS OR ANY OTHER WARRANTY, EXPRESS OR IMPLIED, WHATSOEVER. THE COMPANY SHALL NOT BE LIABLE FOR THE DELAY IN RENDERING SERVICE UNDER THIS WARRANTY OR LOSS OF USE DURING THE TIME THE PRODUCT IS BEING REPAIRED OR REPLACED.

No person or representative is authorized to assume for the Company any liability other than expressed herein in connection with the sale of this product.

Some states or provinces do not allow limitations on how long an implied warranty lasts or the exclusion or limitation of incidental or consequential damage so the above limitation or exclusions may not apply to you. This Warranty gives you specific legal rights, and you may also have other rights, which vary from state to state or province to province.

IN USA: UTStarcom Personal Communications
555 Wireless Blvd.
Hauppauge, NY 11788
(800) 229-1235

IN CANADA: UTStarcom Canada Company
5535 Eglinton Avenue West
Suite# 234
Toronto, ON M9C 5K5
(800) 465-9672

3-WAY CALLING 21

A

ACCESSING THE MENU 16
ADJUSTING THE CALL VOLUME 22
ADJUSTING VOLUME 22
ALARM CLOCK 82
ANSWERING A CALL 20
ANSWERING CALLS 19
AVAILABLE OPTIONS DURING A CALL 23

B

BATTERY HANDLING INFORMATION 14
BLUETOOTH MENU 51

C

CALCULATOR 79
CALENDAR 79
CALLER ID FUNCTION 22
CALLING A NUMBER FROM CONTACTS 21
CALL SETTINGS 67
ANSWER OPTIONS 67
AUTO RETRY 68
DTMF TONES 69
END CALL OPTIONS 68
ONE TOUCH DIAL 69
TTY MODE 68
VOICE PRIVACY 69
CALL WAITING FUNCTION 21
CHARGING YOUR BATTERY 13

CONTACTS 38

CONTACT LIST 38
GROUPS 39
IN CASE OF EMERGENCY 43
MY NAME CARD 45
NEW CONTACT 38
SPEED DIALS 42

D

DISPLAY INDICATORS 10
DISPLAY SETTINGS 57
BACKLIGHT 58
BANNER 57
CLOCK FORMAT 59
DIAL FONTS 59
DISPLAY THEMES 58
MAIN MENU 59
WALLPAPER 58

E

ENTERING LETTERS, NUMBERS & SYMBOLS 34

H

HANDSET DESCRIPTIONS 7

I

INSIDE THE PACKAGE 6
INSTALL BATTERY 12

K

KEYS DESCRIPTIONS 8

M

MAKING A CALL 19
MAKING AN EMERGENCY CALL 24
MAKING AN INTERNATIONAL CALL 20
MEDIA CENTER 87
BROWSE & DOWNLOAD 98
EXTRAS 99
GAMES 96
PICTURES 94
GET NEW PICTURES 94
MY PICTURES 94
ONLINE ALBUM 96
TAKE PICTURE 95
MEDIA CENTER INFO 99
MOBILE WEB 97
MUSIC & TONES 89
GET NEW RINGTONES 89
MY RINGTONES 89
MY MUSIC 91
MY SOUNDS 91
SYNC MUSIC 93
MEMORY 69
CARD MEMORY 71
PHONE MEMORY 70
SAVE OPTIONS 69
MENU SUMMARY 17

- MESSAGING MENU 101**
 - CHAT 108
 - ERASE ALL 108
 - EMAIL 108
 - DRAFTS 106
 - INBOX 105
 - MOBILE IM 107
 - NEW MESSAGE 102
 - PICTURE MESSAGE 103
 - TXT MESSAGE 102
 - VOICE MESSAGE 104
 - SENT 105
 - SETTINGS 109
 - AUTO ERASE 109
 - AUTO SAVE 109
 - CALLBACK # 110
 - ENTRY MODE 109
 - PIC-VOICE AUTO RECEIVE 109
 - QUICK TEXT 110
 - SIGNATURE 110
 - TXT AUTO VIEW 109
 - VOICEMAIL# 110
 - VOICEMAIL 106
- MISSED CALL NOTIFICATION 19**
- MY VERIZON 86**

N

- NAMES TO BE DIALED 25**
- NOTEPAD 84**

O

- ONE, TWO, THREE-TOUCH DIALING 35**

P

- PHONE INFO 72**
 - ICON GLOSSARY 72
 - MY NUMBER 72
 - SOFTWARE UPDATE 72
 - SW/HW VERSION 72
- PHONE SETTINGS 60**
 - AIRPLANE MODE 60
 - LANGUAGE 63
 - LOCATION 63
 - NAM SELECTION 66
 - SECURITY 64
 - SET SHORTCUTS 60
 - SYSTEM SELECT 66
 - VOICE COMMANDS 62

R

- RECENT CALLS 47**
 - ALL 49
 - BLOCKED 49
 - DIALED 48
 - MISSED 47
 - RECEIVED 48
 - RECENT CALLS 47
 - VIEW TIMERS 50
- REMOVE BATTERY 13**

S

- SAFETY 112**
- SOUNDS SETTINGS 54**
 - ALERT SOUNDS 55
 - CALL SOUNDS 54
 - DEVICE CONNECT 56
 - KEYPAD VOLUME 56
 - OPEN/CLOSE SOUND 57
 - POWER ON/OFF 57
 - SERVICE ALERTS 56
- SPEAKERPHONE MODE 22**
- STOP WATCH 85**
- STORING A PHONE NUMBER 28**
 - ADDING A NEW CONTACT 28
 - DELETING 33
 - EDITING CONTACTS ENTRIES 31
 - OPTIONS TO CUSTOMIZE YOUR CONTACTS 28

T

- TURNING THE PHONE ON/OFF 16**

U

- USING AUTO KEYPAD LOCK FUNCTION 23**
- USING THE microSD CARD 88**

V

- VIBRATE ON/OFF MODE 22**
- VOICE COMMANDS 74**
 - CALL <NAME OR #> 74
 - CHECK <ITEM> 75
 - CONTACTS <NAME> 75
 - GO TO <SHORTCUT> 75
 - HELP 76
 - MY VERIZON 76
 - PLAY <PLAYLIST> 76
 - SEND <MSG TYPE> 75
 - VOICE COMMANDS SETTINGS 76

W

- WAIT/PAUSE FEATURE 20**
- WARRANTY 125**
- WORLD CLOCK 83**